



RETRIEVER II—CONDENSATE AND STEAM

Installation Manual



NATIONAL COMBUSTION CO., INC.

104-11 180th Street

Jamaica, NY 11433

Ph: 718-291-8400 Fx: 718-291-6870

The Retriever II: Purpose

The purpose of the RETREIVER II for Condensate & Steam is to recover heat and steam remaining in condensate returns in order to generate hot potable water. When the heat and steam in condensate is not sufficient to heat enough hot water, the RETREIVER II for Condensate & Steam will boost hot water recovery by utilizing live steam from a High Pressure Steam Boiler. What's so important about the Retriever II *is that condensate is still used during a live steam boost.*

The Retriever II: Sequence of Operation

1. When hot domestic water is drawn from the Retriever II, incoming cold water replaces it and the temperature decreases.
2. When the temperature dips *below* the set point programmed on the control, the bypass solenoid valve will close—blocking condensate from returning directly to the condensate return tank—and the condensate solenoid valve will open—forcing condensate into the Retriever II's lower coil for condensate.
3. If the temperature continues to drop either because there is not much condensate or if a lot of domestic water is being used, the steam solenoid valve will open allowing live steam from a high pressure boiler to enter into the Retriever II's upper coil for steam. The condensate coil will continue to accept condensate.
4. When the temperature of the water in the tank reaches the set point, all solenoid valves, except the bypass solenoid valve, will close. No steam or condensate will circulate through the coils of the Retriever II.
5. The vinyl and polyurethane insulation jacket allows less than 1/2 degree per hour standby loss.

Frequently Asked Questions

Q: Do I need steam traps on the heat exchanger outlets?

A: The surface area of the Retriever II's coils is oversized for most applications in laundries and drycleaning plants. Steam traps are usually not necessary because all of the steam will be condensed upon exiting the coils.

Q: If I cool down my condensate, won't that make my boiler work harder?

A: Probably. But you'll recover 970 BTU's per pound of steam condensed in latent heat. Moreover, steam that vents out of a condensate system is pure waste. Also, by using the condensate to heat hot water you're doing without a separately fired hot water heater, which will have significant draft and standby losses.

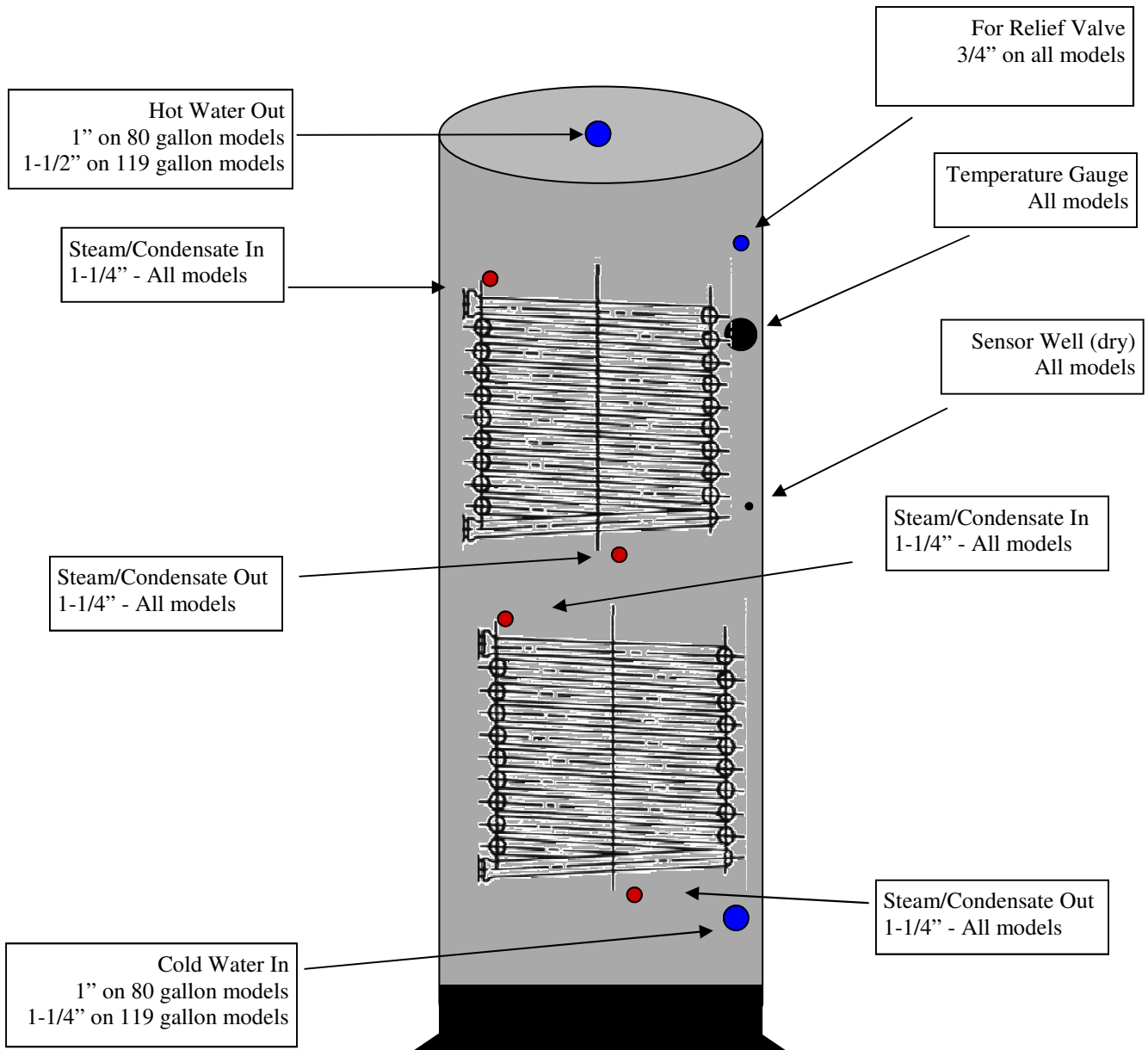

Get the feel of your **Retriever I**:

- Blue connections are potable water side connections
- Red connections are non-potable boiler steam or condensate connections.
- Black ports are dry wells for installation of control sensor.

Note: This diagram is not exactly to scale.

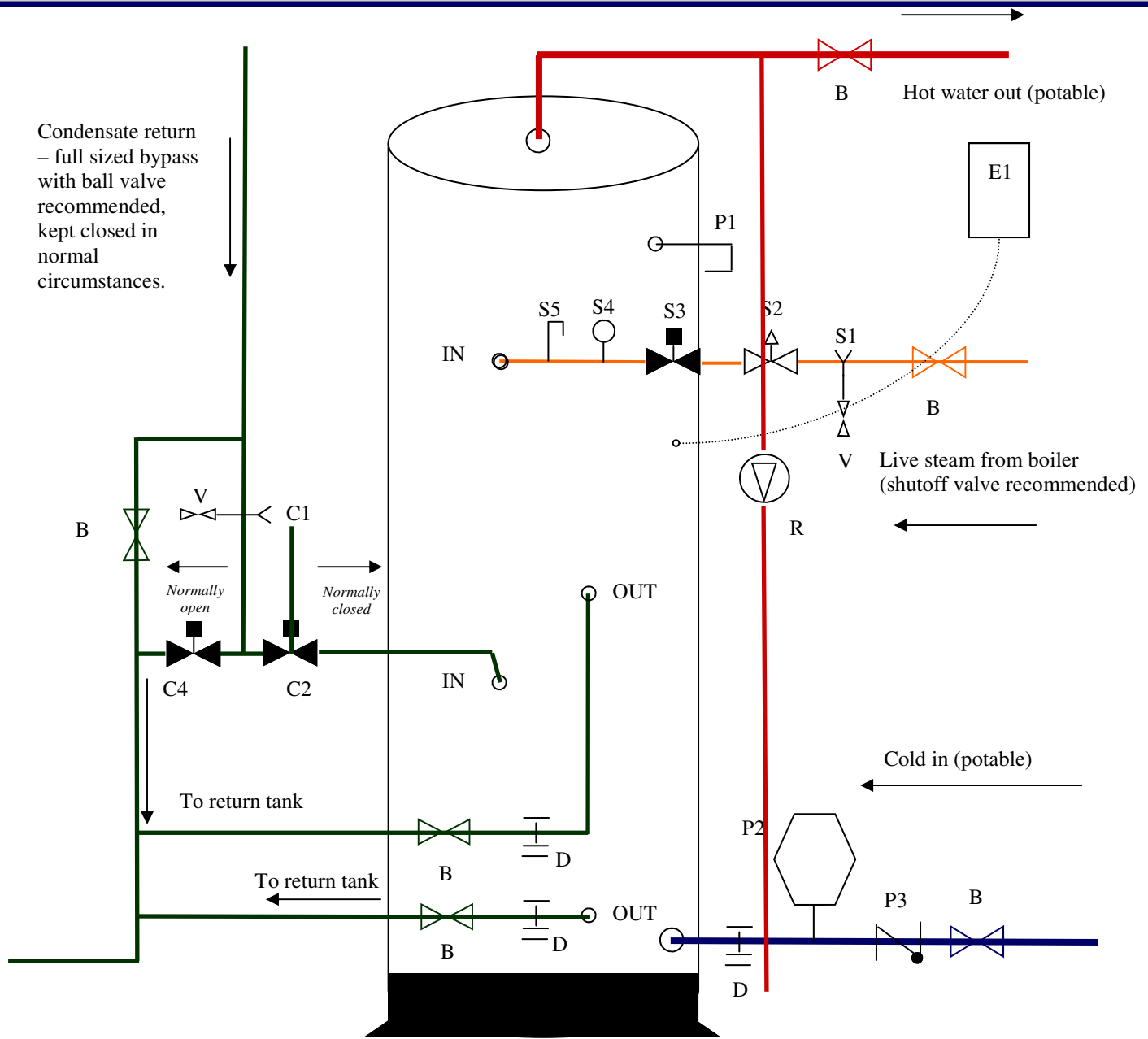

Potable Side Parts	Live Steam Side Parts	Condensate Side Parts	Other Parts
P1. 40XL T&P Relief Valve (included)	S1. 3/4" Y-strainer (included)	C1. 1" Y-Strainer (included)	E1. Honeywell T775B control (included)
P2. Expansion Tank (optional)	S2. Steam Pressure Reducing Valve (included)	C2. 1" NC Condensate Solenoid (Parker 16FS5C, Jefferson 1342BT08T)	E2. Sensor for Honeywell T775B (insert into dry well)
P3. Water Check Valve (not included)	S3. 3/4" NC* Steam Solenoid (Parker 12FS5C, Jefferson 1342BT06T)		V. 3/8" Blowdown Valves—Quantity of 2 (included)
R. Bronze recirculator pump (optional). Install on 1/2" or 3/4" line.	S4. 60 # Pressure Gauge (included)	C4. 1" NO* Condensate Solenoid Valve (Parker 16F240, Jefferson 1342BT08INAT)	D. recommended drain valve (not included).
	S5. 15 # Steam Relief Valve (included)	*NC = Normally Closed *NO = Normally Open	B. Recommended ball valve (not included)

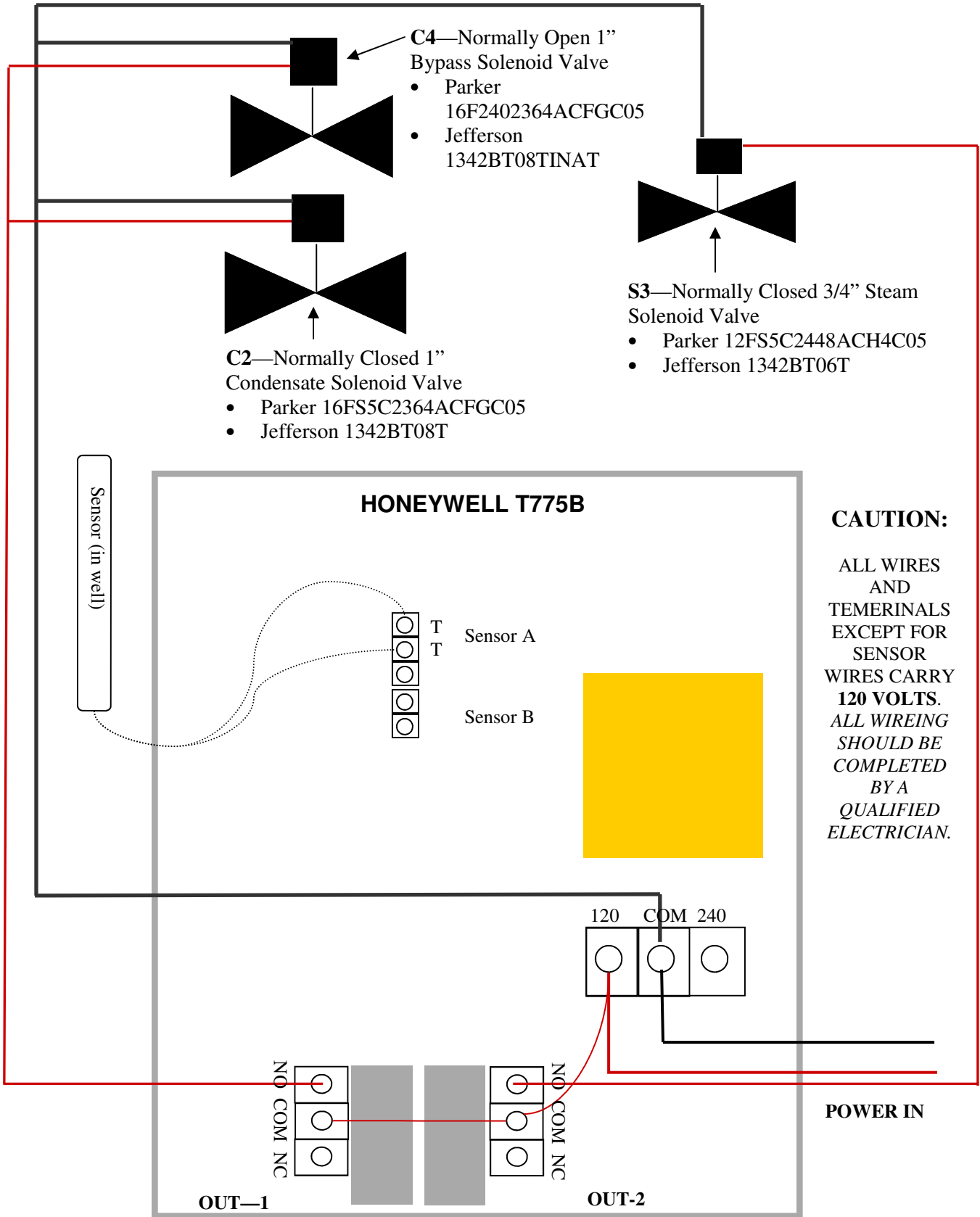

CAUTION:

ALL WIRES AND TERMINALS EXCEPT FOR SENSOR WIRES CARRY **120 VOLTS**. ALL WIRING SHOULD BE COMPLETED BY A QUALIFIED ELECTRICIAN.

Setting the Control

Included with the Retriever is a Honeywell T77B electronic 2-stage control. The way the control is wired, the first stage (or relay) refers to the condensate stage. The second stage refers to the live steam stage. There are a variety of ways you can program the control for different purposes. Here are some examples of control settings for different purposes.

Example 1— Standard Strategy

The following is a common set of control settings for a shirt laundry.

	Setpoint	Differential
Relay 1/Condensate	140	5
Relay 2/Live Steam	130	5

Setpoint refers to the water temperature the stage aims to reach. In the current example, the Retriever will seek to maintain 140 degree water using condensate. If the water temperature drops to 135 degrees (the setpoint minus the differential), the condensate stage will be activated. If the condensate cannot keep up with the hot water usage and the temperature continues to drop to 125 degrees (the setpoint for Relay 2 minus the differential), the live steam will be activated. The live steam will continue to be active until the Retriever reaches 130 degrees. At all times the Retriever will continue to use condensate.

Example 2— Steam Boost to 140

	Setpoint	Differential
Relay 1/Condensate	140	5
Relay 2/Live Steam	140	15

In this example, the condensate also try to maintain the Retriever at 140 degrees. Also, if the temperature drops to 125 degrees, the live steam will come on. What makes this control strategy different is that the live steam will stay activated until the temperature reaches 140 degrees again.

This is a good way to set your controls if you plan on washing shirts in the morning without running steam presses.

Setting the Control

Before powering up the control, wire the control completely to the solenoid valves as diagrammed. Before powering the system, check both the potable system and the steam and condensate system for leaks.

1. Power the control, and wait for it to boot.
2. Now hit the hit the **MENU** button once. You will see two options— **PROGRAM** and **EXIT**. **PROGRAM** will be highlighted. Hit the right arrow key.
3. You will now see three options—**RELAY 1**, **RELAY 2**, and **EXIT**. **RELAY 1** refers to the condensate stage. **RELAY 2** refers to the live steam stage. Highlight **RELAY 1** and hit the right arrow key.
4. You will now see five options under **RELAY 1**—**SETPOINT**, **DIFFRNTL**, **SENSOR**, **HEAT/COOL**, and **EXIT**. **SETPOINT** refers to the temperature you want your hot water to reach. **DIFFRNTL** means differential. That refers to the lag time for the stage to activate. If there is a 5 degree differential and the setpoint is 140 degrees, the stage will be activated at 135 degrees. **SENSOR** refers to which sensor will be used to operate the stage, as it is possible to use two sensors with the control. **HEAT/COOL** refers to whether the stage for **RELAY 1** is a heating stage or a cooling stage. Our stages are always heating stages.
5. Navigate to **SETPOINT** using the up and down arrow keys. Hit the right arrow key. Now use the up and down arrow keys to set your water temperature setpoint. When you are done, hit the left arrow key to return.
6. Navigate to **DIFFRNTL** using the up and down arrow keys. Hit the right arrow key. Set the differential in the same way you set the SETPOINT. For the condensate stage, a 5 degree differential will usually work very well. When you are done, hit the left arrow key to return.
7. Navigate to **SENSOR** and set the setting to **SENSOR**. When you are done, hit the left arrow key to return.
8. Navigate to **HEAT/COOL** and set the setting to **HEAT**. When you are done, hit the left arrow key to return.
9. Hit the left arrow key one more time to reach the **RELAY 1/RELAY 2** menu. Navigate to RELAY 2 and hit the right arrow key.
10. Now repeat your settings. The only difference between RELAY 1 and RELAY 2 should be the **SETPOINT** and/or the **DIFFRNTL** (see the examples on the previous page for control strategies. The **SENSOR** and HEAT/COOL settings will be the same, **SENSOR A**.
11. When you are done with all settings, press the home button.

Problem	Cause	Solution
Water in tank exceeds set point temperature	1) Sensor is not positioned properly 2) Sensor is not wired properly 3) A solenoid valve is stuck open 4) Sensor is malfunctioning. 5) Hot water is stacking at top of tank.	1) Check sensor, use thermally conductive putty. 2) Check wiring of sensory, check Honeywell rec. for type of wire. 3) Clean or rebuild solenoid valves. 4) Replace sensor. 5) Install recirculation loop.
Tank uses too much live steam from a steam boiler, hot water recovery is not a problem.	Stage 2 set point is too close to stage 1, or stage 2 differential is too low.	Decrease stage 2 set point, or increase stage 2 differential.
Stage 1 is energized, but piping leading to the heat exchanger is always cold.	1) Condensate valve is not opening. 2) Bypass valve is not closing. 3) Condensate strainer is clogged.	1) Clean or rebuild condensate valve. 2) Clean or rebuild bypass valve. 3) Blow down 1" Y-Strainer.
Water-side relief valve is blowing when no potable water is used.	1) Expansion tank missing or not sufficiently pressurized. 2) Tank is overheating.	1) Install tank or charge tank to street pressure. 2). See above.
Water-side relief valve is blowing when potable water is used.	High water pressure or water hammer coming from main supply.	Install a pressure reducing valve on the cold water side of the tank (expansion tank must also be installed).
Steam relief valve is blowing.	High steam pressure.	Adjust and/or replace steam pressure regulator.

General Maintenance Notes:

1. Blow down your Y-strainers. This will lengthen the life of your solenoid valves.
2. Recharge your expansion tank. If the expansion tank loses air pressure, it'll become useless. Make sure you charge your expansion tank so that the air pressure equals the water pressure coming from the street.
3. Make sure that the control stays dry. Like any electrical component, when wet it will malfunction and will likely be destroyed.
4. If you have a hard water situation, occasionally de-lime the tank utilizing a de-liming kit (available at most plumbing supplies).
5. DO call NATCO with questions. You can reach us at the following:

National Combustion Co., Inc.

104-11 180th Street

Jamaica, NY 11433

Ph: 718-291-8400

Fx: 718-291-6870

 Email: technical@nationalcombustion.com

National Combustion Co., Inc. warrants the Retriever tank and integral heat exchangers for defects in materials and workmanship for **5 years** after the certified date of installation **or 5 years after** the date of purchase, whichever can be proven. If the date of installation is greater than one (1) year past the date of purchase, the date of purchase + one (1) year will be the date for determining whether the Retriever tank and integral heat exchanger are warranted.

National Combustion Co., Inc. warrants all other components for defects in material and workmanship for 1 year of the date of purchase. The warranties of all other parts are subjects to the terms and conditions of the various manufacturers of those components.

National Combustion Co., Inc. reserves the right to inspect tanks claimed by the purchaser to be defective. Retriever tanks found to have defects in the tank or heat exchangers shall be replaced with the closest available current model. National Combustion Co., Inc. will provide a replacement, but is not liable for costs of (i) shipping replacement tanks, (ii) labor for installation of a replacement and removal and disposal of a defective tank, and (iii) inconveniences due to a defective water heater. National Combustion Co., Inc. is not responsible for damage caused by a leaking tank or heat exchanger. The Retriever tank should be positioned so that the flow of leaked water will not cause damage.

National Combustion Co., Inc. does not warranty Retrievers in the case or malfunctions caused by or in:

- 1) Improper installation or maintenance accorded to these printed installation instructions.
- 2) Retrievers that have been moved from their initial site of installation.
- 3) Water freezing in the tank or heat exchanger(s).
- 4) Retrievers for which the tank or heat exchanger(s) have been repaired without express authorization from National Combustion Co., Inc.
- 5) Excessive pressure due to extraordinary water pressure or failure to properly install and maintain an expansion tank.
- 6) Failure to maintain tank to prevent buildup of lime and scale.
- 7) Operation of the Retriever in a corrosive environment.
- 8) Usage of the Retriever tank and heat exchangers for purposes other than heating water for potable use.
- 9) Flood, fires, wind, or lightning.

THIS WARRANTY IS NOT-TRANSFERABLE AND IS FOR THE BENEFIT OF THE ORIGINAL PURCHASER ONLY.

IMPORTANT:

To certify an installation date, call, write, or email National Combustion Co., Inc, with the following information:

Name of Purchaser
Address of Installation
Name of Dealer Purchased From
Name of Contractor Responsible for Installation
Serial Number

All correspondence to the National Combustion Co., Inc. warranty department can be addressed to the following:

National Combustion Co., Inc.
104-11 180th Street
Jamaica, NY 11433
warranties@nationalcombustion.com
Ph: 718-291-8400 Fx: 718-291-6870