

NATCO



SUPER-EFFICIENCY

Installation, Operation Manual, and Service Manual for Super-E
SP (Spark) High-Efficiency Water Heater Models:

SE-199-80

SE-199-119

National Combustion Co., Inc.

104-11 180th Street

Jamaica, NY 11433

Ph: 718-291-8400 Fx: 718-291-6870

www.nationalcombustion.com



Recognize this symbol as an indication of important Safety Information!



Do Not Destroy this Manual. Please read carefully and keep in a safe place for Future Reference.

⚠ NOTICE

This water heater is designed for use in a commercial application. The installation and maintenance of it should be performed by qualified, licensed service personnel.

⚠ WARNING

Read and review this entire manual with special emphasis on the Venting and Operation Sections prior to any installation work.

⚠ CALIFORNIA PROPOSITION 65 WARNING

This product contains chemicals known to the State of California to cause cancer, birth defects and other reproductive harm.

⚠ WARNING

If the information in these instructions are not followed exactly, a fire or explosion may result causing property damage, personal injury or death.

⚠ FOR YOUR SAFETY!

- Do not store or use gasoline or other flammable vapors or liquids or other combustible materials in the vicinity of this or any other appliance. To do so may result in an explosion or fire
- WHAT TO DO IF YOU SMELL GAS
 - Do not try to light any appliance.
 - Do not touch any electrical switch; do not use any phone in your building.
 - Immediately call your gas supplier from a neighbor's phone. Follow the gas supplier's instructions.
- If you cannot reach your gas supplier, call the fire department.
- Do not return to your building until authorized by the gas supplier or fire department.
- Improper installation, adjustment, alteration, service or maintenance can cause injury, property damage or death. Refer to this manual. Installation and service must be performed by a qualified installer service agency or gas supplier.

SPECIFICATIONS

RECOVERY CAPACITIES

Recovery in U.S. Gallons/Hr. (GPH) and Liters/Hr. (LPH) at Various Temperature Rises

MODEL NUMBER	INPUT (BTU/HR) NAT. & LP	THERMAL EFFICIENCY	UNITS	40°F (22.2°C)	50°F (27.8°C)	60°F (33.3°C)	70°F (38.9°C)	80°F (44.4°C)	90°F (50.0°C)	100°F (55.6°C)	110°F (61.1°C)	120°F (66.7°C)
SE199-80	199,000	95%	GPH	573	458	382	327	286	255	229	208	191
SE199-119			LPH	2169	1735	1446	1239	1084	964	867	789	723

Recovery rating is based on thermal efficiencies obtained in Intertek testing laboratory.

All models exceed the minimum energy efficiency requirements of current ASHRAE 90.1 requirements.

MAXIMUM DELIVERY

In U.S. Gallons and Liters (Includes useable storage and recovery for indicated times)

MODEL NUMBER	GALLONS/ LITERS	MAX SETPOINT	INPUT (BTU/HR) NAT. & LP	TEMP. RISE	UNITS	5 MIN.	10 MIN.	15 MIN.	20 MIN.	30 MIN.	45 MIN.	1 HR.	2 HR.	3 HR.	MIN. TO RECOVER CONTENTS
SE199-80	80 303	160° 71°C	199,000	100°F	GAL.	75	94	113	132	171	228	285	514	743	21
				37.7°C	LTR.	284	357	429	501	646	863	1079	1947	2814	
SE199-119	119 450	160° 71°C	199,000	100°F	GAL.	102	121	141	160	198	255	312	542	771	31
				37.7°C	LTR.	338	460	532	604	749	966	1183	2050	2918	

All models have a maximum setpoint of 160°F with the exception of the HE55-160 and HE55-199 booster models. The HE55-160 and HE55-199 have a maximum setpoint of 180°F.

* NOTE: The 180° F models are shipped with all necessary components for an approved installation (see Booster Installation Kit for component list on Page 7.)

DIMENSIONAL INFORMATION

All dimensions shown in English and Metric

MODEL NUMBER	UNITS	HEIGHT	WIDTH	DEPTH	VENT	WATER CONNECTIONS		APPROX SHIPPING WT.
						INLET	OUTLET	
HE80-199	inches	72	23 1/2	32	3*	1-1/2	1-1/2	235 lbs.
	mm	1854	597	813	76	38	38	106 kgs
HE119-199	inches	73	27	36	3*	1-1/2	1-1/2	405 lbs.
	mm	1854	686	914	76	38	38	184 kgs

0" CLEARANCE TO COMBUSTIBLES ON ALL SUPER-E SP UNITS, HOWEVER, A 24" (61 cm) CONTROL PANEL SERVICE CLEARANCE IS RECOMMENDED.

All models require a 120V power source.

TABLE OF CONTENTS

<i>Part 1: General Safety Precautions</i>	4-5
<i>Part 2: Installation</i>	6-10
Local Installation Regulations	6
Location	6
Temperature and Pressure Relief Valve	6
Expansion Tank	6
Potable Water Connections	7
Lighting and Operating Instructions	8
Electrical Connection	9
Gas Connection	9-10
<i>Part 3: Venting, Combustion Air & Condensate Removal</i>	11-17
General	11
Approved Materials for Exhaust Vent and Intake Air	11
Exhaust Vent and Intake Air Vent Pipe Locations	11-13
Exhaust Vent and Intake Air Vent Sizing	14
Longer Vent Runs	14
Exhaust Vent and Intake Air Pipe Installation	14-15
Very Important Set-up Instructions	15
Concentric Vent	16
Vent Length Maximum Reference Chart	17
<i>Part 4: Operation</i>	18-20
Overall Appliance and Control Operation	18
Status Mode	18
Test Mode	18-19
Operating Instructions	20
Shutdown Procedure	20
Prevent Combustion Air Contamination	20
Corrosive Contaminants and Source Products to Avoid	21
Condensate	21
<i>Part 5: Components and Wiring</i>	22-23
Components Diagram	22
Wiring Diagram	23
<i>Part 6: Troubleshooting</i>	24-25
<i>Part 7: How to Get Your Super-E Serviced</i>	26
<i>Part 8: Standard Piping Diagrams</i>	27
1 Unit, Standard	27
2 Units without Recirculator	28
2 Units with Recirculator	29
<i>Part 9: Warranty</i>	30

PART 1: GENERAL SAFETY PRECAUTIONS

Be sure to read and understand the entire Use & Care Manual before attempting to install or operate this water heater. Pay particular attention to the following General Safety Precautions. Failure to follow these warnings could result in a fire or explosion, causing property damage, bodily injury or death. Should you have any problems understanding the instructions in this manual, STOP, and get help from a qualified installer or service technician or the gas supplier.

⚠ WARNING

Gasoline, as well as other flammable materials and liquids (adhesives, solvents, etc.), and the vapors they produce, are extremely dangerous. DO NOT handle, use or store gasoline or other flammable or combustible materials anywhere near or in the vicinity of a water heater. Be sure to read and follow the warning label pictured below and other labels on the water heater, as well as the warnings printed in this manual. Failure to do so can result in property damage, bodily injury, or death.

⚠ DANGER

Failure to install and properly vent the water heater to the outdoors as outlined in the Venting Section of this manual can result in unsafe operation of the water heater. To avoid the risk of fire, explosion, or asphyxiation from carbon monoxide, never operate this water heater unless it is properly vented and has an adequate air supply for proper operation. Be sure to inspect the vent system for proper installation at initial start-up and at least annually thereafter. Refer to maintenance section of this manual for more information regarding vent system inspections.

⚠ DANGER

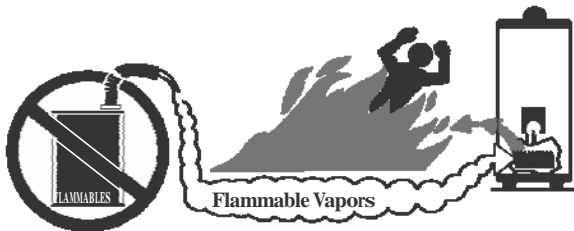

⚠ Vapors from flammable liquids will explode and catch fire causing death or severe burns.

Do not use or store flammable products such as gasoline, solvents or adhesives in the same room or area near the water heater.

Keep flammable products:

1. far away from heater,
2. in approved containers,
3. tightly closed and
4. out of children's reach.

Installation:

Do not install water heater where flammable products will be stored or used unless the main burner and pilot flames

Water heater has a main burner and pilot flame. The pilot flame:

1. which can come on at any time and
2. will ignite flammable vapors.

Vapors:

1. cannot be seen,
2. are heavier than air,
3. go a long way on the floor and
4. can be carried from other rooms to the pilot flame by air currents.

are at least 18" above the floor. This will reduce, but not eliminate, the risk of vapors being ignited by the main burner or pilot flame.

Read and follow water heater warnings and instructions. If owners manual is missing, contact the retailer or manufacturer.

⚠ DANGER

LIQUEFIED PETROLEUM MODELS

- Propane, or LP gas, must be used with great caution.
- It is heavier than air and will collect first in lower areas making it hard to detect at nose level.
- Make sure to look and smell for LP leaks before attempting to light appliance. Use a soapy solution to check all gas fittings and connections. Bubbling at a connection indicates a leak that must be corrected. When smelling to detect an LP leak, be sure to sniff near the floor.
- Gas detectors are recommended in LP applications and their installation should be in accordance with the manufacturer's recommendations and/or local laws, rules, regulations or customs.
- It is recommended that more than one method be used to detect leaks in LP applications.

IF LP GAS IS PRESENT OR SUSPECTED:

- DO NOT attempt to find the cause yourself;
- DO NOT try to light any appliance;
- DO NOT touch any electrical switch;
- DO NOT use any phone in your building.
- Leave the house immediately and make sure your family and pets leave also.
- Leave the doors open for ventilation and contact the gas supplier, a qualified service agency or the fire department.
- Keep the area clear until the service call has been made, the leak is corrected, and a qualified agency has determined the area to be safe.

⚠ WARNING

Both LP and natural gas have an odorant added to help detection. Some people may not physically be able to smell or recognize this odorant. If unsure or unfamiliar about the smell associated with LP or natural gas, ask the gas supplier. Other conditions, such as "Odorant Fade", which causes the odorant to "fade", or diminish in intensity can also hide or camouflage a gas leak.

⚠ DANGER

Water heaters utilizing Liquefied Petroleum gas (LP) are different from natural gas models. A natural gas heater will not function safely on LP gas and vice versa. No attempt should ever be made to convert a heater from natural gas to LP gas. To avoid possible equipment damage, personal injury or fire: DO NOT connect this water heater to a fuel type not in accordance with unit rating plate. Propane gas for propane units. Natural gas for natural gas units. These units are not certified for any other type fuel.

PART 1: GENERAL SAFETY PRECAUTIONS cont'd

⚠️ WARNING

LP appliances should not be installed below-grade (for example, in a basement) if such installation is prohibited by federal, state and/or local laws, rules, regulations, or customs.

To meet commercial water use needs, the thermostat on this water heater is adjustable up to 160°F (71°C). However, water temperatures over 125°F (52°C) can cause severe burns instantly or death from scalds. This is the preferred starting point for setting the controls for supplying general purpose hot water.

Safety and energy conservation are factors to be considered when setting the water temperature on the thermostat. The most energy efficient operation will result when the temperature setting is the lowest that satisfies the needs consistent with the application.

Maximum water temperatures occur just after burner has shut off. To find temperature of the water being delivered, turn on a hot water faucet and place a thermometer in the hot water stream and read the thermometer.

The following chart details the relationship of water temperature and time with regard to scald injury and may be used as a guide in determining the safest water temperature for your applications.

TIME / TEMPERATURE RELATIONSHIPS IN SCALDS

Temperature	Time to Produce Serious Burn
120°F (49°C)	More than 5 minutes
125°F (52°C)	1½ to 2 minutes
130°F (54°C)	About 30 seconds
135°F (57°C)	About 10 seconds
140°F (60°C)	Less than 5 seconds
145°F (63°C)	Less than 3 seconds
150°F (66°C)	About 1½ seconds
155°F (68°C)	About 1 second

Table courtesy of Shriners Burn Institute

The temperature of the water in the heater can be regulated by setting the temperature on the electronic thermostat. To comply with safety regulations, the thermostat was set at its lowest setting before the water heater was shipped from the factory. See the section titled SET POINT ADJUSTMENT PROCEDURE to set the electronic thermostat.

⚠️ DANGER

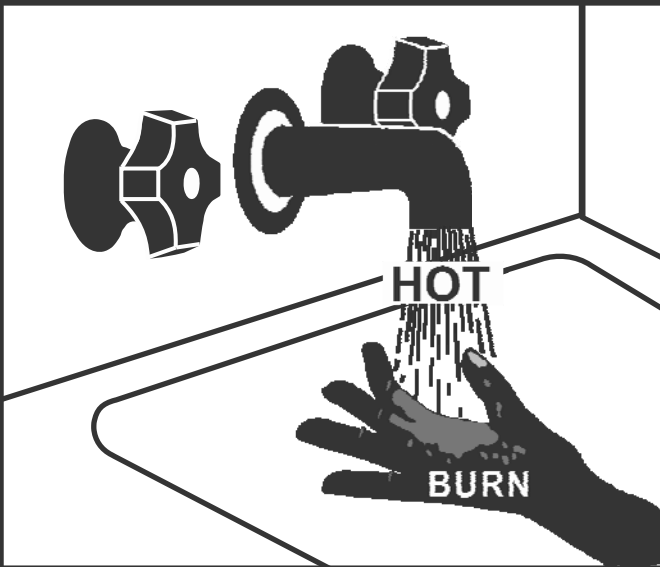

Water temperature over 125°F can cause severe burns instantly or death from scalds.

Children, disabled and elderly are at highest risk of being scalded.

See instruction manual before setting temperature at water heater.

Feel water before bathing or showering.

Temperature limiting valves are available, see manual.

⚠️ DANGER

There is a Hot Water SCALD Potential if the thermostat is set too high.

NOTE: When this water heater is supplying general purpose hot water requirements for use by individuals, a thermostatically controlled mixing valve for reducing point of use water temperatures is recommended to reduce the risk of scald injury. Contact a licensed plumber or the local plumbing authority for further information.

PART 2: INSTALLATION

WARNING

Read and review this entire manual with special emphasis on the Venting Sections and Operation Sections prior to any installation work.

A. LOCAL INSTALLATION REGULATIONS

This water heater must be installed in accordance with these instructions, local codes, utility company requirements, and/or in the absence of local codes, the latest edition of the National Fuel Gas Code ANSI Z22.1 in the United States or CAN/CSA B149.1 installation code in Canada.

The water heater must be located or protected so it is not subject to physical damage, for example, by moving objects, area flooding, etc.

CAUTION

The water heater should not be located in an area where leakage of the tank or connections will result in damage to the area adjacent to it or to lower floors of the structure. When such areas cannot be avoided, it is recommended that a suitable catch pan, adequately drained, be installed under the water heater.

NOTE: Auxiliary catch pan installation MUST conform to the applicable local codes

B. LOCATION

Choose a location for your water heater centralized to the piping system, along with consideration to vent pipe length. As the length of vent pipe increases, the firing rate of the appliance decreases. You must also locate the Super-E SP where it will not be exposed to below freezing temperatures. Additionally, you will need to place the water heater so that the controls, drain, inlet/outlet, and gas valve are easily accessed. This appliance must not be installed outdoors, as it is certified as an indoor appliance, and must be kept vertical and on a level surface. Also, care must be exercised when choosing the location of this appliance where leakage from the relief valve, leakage from related piping, or leakage from the tank or connections, will not result in damage to the surrounding areas or to the lower floors of the building. **A water heater should always be located in an area with a floor drain or installed in an adequately drained catch pan suitable for water heaters.** Proper clearance must be provided around the Super-E SP as follows: Sides, bottom, top, and back are 0" (zero clearance). Front of the appliance needs 24" (61 cm) service clearance minimum. This front service may be achieved by a non-rated or combustible door or access panel; providing the 24" (61 cm) service clearance is achieved when the door is opened or panel is

removed. **This water heater must not be located near flammable liquids such as gasoline, adhesives, solvents, paint thinners, butane, liquefied propane, etc. as the controls of this appliance could ignite those vapors, causing an explosion.**

C. TEMPERATURE AND PRESSURE RELIEF VALVE

A new combination temperature and pressure relief valve, complying with the Standard for Relief Valves and Automatic Gas Shutoff Devices for Hot Water Supply Systems, ANSI Z21.22 or Standard CSA 4.4, must be installed in the opening provided on the water heater at the time of installation. No valve is to be placed between the relief valve and the water heater. For circulating tank installation, the separate storage tank(s) must have similar protection. The pressure rating of the relief valve must not exceed the maximum working pressure as marked on the front of the water heater. The Btu/h rating of the relief valve must equal or exceed the Btu/h input of the water heater as noted on its rating plate. Connect the outlet of the relief valve to a suitable open drain. The discharge line must pitch downward from the valve to allow complete draining (by gravity) of the relief valve and discharge line, and must be no smaller than the outlet of the relief valve. The end of the discharge line should not be threaded or concealed and should be protected from freezing. No valve of any type, restriction or reducer coupling should be installed in the discharge line. In the U.S., local codes shall govern the installation of relief valves. In Canada, use CAN/CSA B149.1.

D. EXPANSION TANK

A potable hot water expansion tank may be required to offset the water expansion as the water is heated. In most city plumbing systems, the water meter has a no return or back flow device built into the system to prevent back flowing of water back into city mains. Back flow preventers may be found on all incoming water supplies. Under these circumstances, you will need a hot water expansion tank listed for potable water use. The expansion tank should be located on the cold inlet piping close to the water heater. **The expansion tank must be suitable for hot potable water.**

WARNING

The manufacturer's warranty does not cover any damage or defect caused by installation or attachment or use of any special attachments such as energy saving devices (other than those authorized by the manufacturer) into, onto, or in conjunction with the water heater. The use of such unauthorized devices may shorten the life of the water heater and may endanger life and property. The manufacturer disclaims any responsibility for such loss or injury resulting from the use of such unauthorized devices.

E. DOMESTIC WATER CONNECTIONS

The water connections must be installed in accordance with all national and local plumbing codes, or any prevailing standard. **NEVER USE DIELECTRIC UNIONS OR GALVANIZED STEEL FITTINGS ON SUPER-E SP CONNECTIONS.** The inlet and outlet connections are 1" on the 55 gallon models and 1-1/2" on the 80 and 119 gallon models. On the cold inlet, install a 1" brass tee on the 55 gallon models, or a 1-1/2" brass tee on the 80 and 119 gallon models. On the run of the 1" brass tee install, with pipe sealant, compound a 1" brass drain cock or its equivalent (*not supplied*). Into the branch of the 1" or 1-1/2" brass tee install a copper male adapter to match with the copper plumbing system. For convenience, you may install a shut off valve and a union in the cold inlet piping to ease servicing in the future. If there is a back flow preventer, or any type of a check valve in the system, then you must install an additional tee for a suitable potable thermal expansion tank. (See section on Expansion Tank.) In the hot outlet connection, (top left), install a suitable adapter to match the copper tubing of the plumbing system. A thermal trap or heat trap loop may be installed here to provide additional energy savings and prevent thermal siphoning of domestic hot water. If required, a domestic hot water tempering/anti-scald valve should be installed into the hot water line to prevent the maximum outlet water temperature from exceeding 125°F (52°C) to prevent scald injury.

G. LIGHTING AND OPERATING INSTRUCTIONS

⚠ WARNING

If the information in this manual is not followed exactly, a fire or explosion may result causing property damage, personal injury or loss of life.

Do not store or use gasoline or other flammable vapors and liquids in the vicinity of this or any other appliance.

WHAT TO DO IF YOU SMELL GAS

- Do not try to light any appliance.
- Do not touch any electrical switch: do not use any phone in your building.
- Immediately call your gas supplier from a neighbor's phone. Follow the gas supplier's instructions.
- If you cannot reach your gas supplier, call the fire department. Installation and service must be performed by a qualified installer, service agency or the gas supplier.

FOR YOUR SAFETY READ BEFORE OPERATING

WARNING: If you do not follow these instructions exactly, a fire or explosion may result, causing property damage, personal injury or loss of life.

A. This appliance does not have a pilot. It is equipped with an ignition device which automatically lights the burner. Do not try to light the burner by hand.

B. BEFORE OPERATING smell all around the appliance area for gas. Be sure to smell next to the floor because some gas is heavier than air and will settle on the floor.

WHAT TO DO IF YOU SMELL GAS

- Do not try to light any appliance
- Do not touch any electric switch; do not use any phones in your building
- Immediately call your gas supplier from a neighbor's phone. Follow the gas suppliers' instructions.

- If you cannot reach your gas supplier, call the fire department.

C. Use only your hand to turn the gas control knob. Never use tools. If the handle will not turn by hand, don't try to repair it, call a qualified service technician. Force or attempted repair may result in a fire or explosion.

D. Do not use this appliance if any part has been under water. Immediately call a qualified service technician to inspect the appliance and to replace any part of the control system and any gas control which has been under water.

OPERATING INSTRUCTIONS

1. STOP! Read the safety information above.
2. Set the thermostat to lowest setting.
3. Turn off all electric power to the appliance.
4. This appliance is equipped with an ignition device which automatically lights the burner. Do not try to light the burner by hand.
5. Remove front cover.
6. Turn gas shutoff valve to "off". Handle will be across the piping, do not force.
7. Wait five (5) minutes to clear out any gas. If you then smell gas, STOP! Follow "B" in the safety information above on this label. If you don't smell gas, go to next step.
8. Turn gas shutoff valve to "on". Handle will be in line with piping.
9. Install Front Cover.
10. Turn on all electric power to appliance.
11. Set thermostat to desired setting.
12. If the appliance will not operate, follow the instructions "To Turn Off Gas To Appliance" and call your service technician or gas supplier.

GAS VALVE
ON

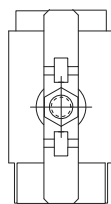

GAS VALVE
OFF

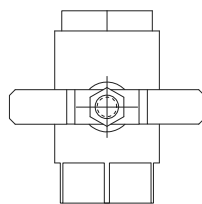

TO TURN OFF GAS TO APPLIANCE

1. Set the thermostat to lowest setting.
2. Turn off all electric power to the appliance if service is to be performed.
3. Remove Front Cover.
4. Turn gas shutoff valve to "off". Handle will be across the piping. Do not force.
5. Install Front Cover.

LP-175 Rev. 4 3-11-08

⚠ WARNING

Tank MUST be full of water before power is turned on. Heat exchanger coil WILL BE DAMAGED if energized even for a short time while the tank is dry. The water heater's warranty does not cover damage or failure resulting from operation with an empty or partially empty tank. (Reference is made to the limited warranty for complete terms and conditions)

H. ELECTRICAL CONNECTION

The electrical connection for the Super-E SP is on the left side of the combustion shroud. There is a 1/2" knock-out location for electrical connection. All electrical wiring must be performed by a qualified licensed electrician, and in accordance with National Electrical Code and Canadian Electrical Code, or to the applicable local codes and standards. The electrical requirements are for standard 120 volts, 60 Hz., 10 amp service. It is recommended that an electrical disconnect switch be placed near the water heater, and that the connection to the Super-E SP be made using 3/8" extra-flex, or 3/8" greenfield (or equivalent). **This unit must be wired with #14 AWG, and fused for no more than 15 amps. It is of extreme importance that this unit be properly grounded and be connected with proper polarity!** Ground the water heater by connecting the green wire in the electrical access compartment directly to the main building ground system. **It is very important that the building system ground is inspected by a qualified electrician prior to making this connection.** Once all connections have been made, the electrical access may be closed. It is very important that the electrical power is not turned on until gas and venting connections are completed and the tank is full of water.

I. GAS CONNECTION

Refer to the below table to size the supply piping to minimize pressure drop between meter or regulator and unit. In Canada, use table found in CAN/CSA B149.1

Maximum Capacity of Pipe in Cubic Feet of Gas per Hour for Gas Pressures of 0.5 psi or Less and a Pressure Drop of 0.3 Inch water Column

Gas Table

(Nominal Iron Pipe Size (inches))	Internal Diameter (inches)	Length of Pipe (Feet)							
		10	20	30	40	50	60	70	
3/4	.824	278	190	152	130	115	105	96	BTU'S PER HOUR x1,000
1 1/4	1.049	520	350	285	245	215	195		
1 1/2	1.380	1,050	730	590	500	440	400	370	
1 1/2	1.610	1,600	1,100	890	760	670	610	560	

(Nominal Iron Pipe Size (inches))	Internal Diameter (inches)	Length of Pipe (Feet)							
		80	90	100	125	150	175	200	
3/4	.824	90	84	79	72	64		55	BTU'S PER HOUR x1,000
1 1/4	1.049	170	160	150	130	120		100	
1 1/2	1.380	350	320	305	275	250		210	
1 1/2	1.610	530	490	460	410	380		320	

It is recommended that a soapy solution be used to detect leaks. Bubbles will appear on the pipe to indicate a leak is present. The gas piping must be sized for the proper flow and length of pipe, to avoid excessive pressure drop. Both the gas meter and the gas regulator must be properly sized for the total gas load. **If you experience a pressure drop greater than 1" WC, the meter, regulator or gas line is undersized or in need of service.** You can attach a manometer to the incoming gas drip leg, by removing the cap and installing the manometer. The gas pressure must remain between 3.5" WC and 14" WC during stand-by (static) mode and while in operating (dynamic) mode at full output. **If an in-line regulator is used, it must be a minimum of 10 feet from the Super-E SP. It is very important that the gas line is properly purged by the installer, gas supplier or utility. Failure to properly purge the lines or improper line sizing, will result in ignition failure.** This problem is especially noticeable in NEW LP installations and also in empty tank situations. This can also occur when a utility company shuts off service to an area to provide maintenance to their lines. The gas valve must not be replaced with a conventional gas valve under any circumstances. As an additional safety feature in the Super-E SP water heater, the gas valve in this appliance has a flanged connection to the swirl plate and blower.

Gas supply shall not exceed a maximum inlet pressure of 14" water column (350 mm), 1/2 pound pressure (3.4 kPa), between 3.5" WC and 14" WC (natural and propane). The entire piping system, gas meter, and regulator must be sized properly to prevent a pressure drop greater than 0.5" of water column as stated in the National Fuel Gas Code. Gas pressure information is listed on the rating plate. **It is very important that you are connected only to the type of gas noted on the rating plate; "LP" or propane gas or "Nat" natural gas.** All gas connections must be approved by the local gas supplier or utility in addition to the governing authority prior to turning the gas supply on. The nipple provided for the inlet gas connection is 1/2", and it is mandatory that a 3/4" to 1/2" reducing bushing (provided) is used, threaded into the branch of a 3/4" tee, and a drip leg fabricated, as per the National Fuel Gas Code and in Canada refer to CAN/CSA B149.1.

You must ensure that the entire gas line to the reducing bushing connection at the Super-E SP is no smaller than 3/4".

⚠ CAUTION

THE USE OF FLEXIBLE GAS CONNECTORS IS NOT RECOMMENDED. HOWEVER, IF USED, IT IS IMPERATIVE THAT THEY ARE SIZED CORRECTLY. FLEXIBLE GAS CONNECTORS MUST HAVE A MINIMUM ID OF 3/4". A MINIMUM 3/4" ID MUST BE MAINTAINED TO AVOID RESTRICTION OF GAS FLOW! NEVER REDUCE THE GAS SUPPLY LINE BELOW 3/4"! In Canada, refer to CAN/CSA B149.1 for approved connections.

Once all the inspections have been performed, the piping system must be leak tested. If the leak test pressure is higher than the maximum permissible inlet pressure, you must isolate the Super-E SP from the gas line before testing. In order to do this, you must disconnect the union and cap the inlet gas line. *In the event the gas valve is exposed to a pressure greater than 1/2 PSI, 14" water column, the gas valve must be replaced.*

Failure to follow all precautions could result in fire, explosion or death!

It is recommended that a soapy solution be used to detect leaks. Bubbles will appear and indicate a leak is present. The gas piping must be sized for the proper flow and length of pipe to avoid unacceptable pressure drop. Both the gas meter and the gas regulator must be properly sized for the total gas load. If you experience a pressure drop greater than 1" W.C., the meter or regulator or gas line may be undersized or in need of service. On the inlet side of the gas valve, there is a 1/8" NPT plug. This plug can be removed to attach a manometer. You can attach a meter to the incoming gas drip leg by removing the cap and installing the meter. The gas pressure must remain between 3.5" and 14" of water column during stand-by and unit running heat cycle. I

an in-line regulator is used, it must be a minimum of 10 feet from the Super-E SP. It is very important that the gas line is properly purged by the installer, gas supplier or utility. Failure to properly purge the lines or improper line sizing, will result in ignition failure of the Super-E SP.

The gas valve is a special gas valve which has a Pressure Augmented Regulator feature, as well as negative outlet pressure. This valve must not be replaced with a conventional valve under any circumstances. Make sure valve is in the "OFF" position prior to turning gas supply on. As an additional safety feature, this valve has a left hand thread on the outlet end, and a special tamper resistant electrical connector.

⚠ WARNING

Never use open flame to test for gas leaks, as bodily injury or property damage could result.

⚠ WARNING

DO NOT exceed input shown on water heater rating label.

PART 3: VENTING, COMBUSTION AIR & CONDENSATE REMOVAL

⚠ WARNING

This vent system will operate with a positive pressure in the flue gas vent pipe. Do not connect vent connectors serving appliances vented by natural draft into any portion of mechanical draft systems operating under positive pressure. Follow the venting instructions below carefully. Failure to do so may result in severe personal injury, death, or substantial property damage.

A. GENERAL

1. Install the water heater venting system in accordance with these instructions and with the National Fuel Gas Code, ANSI Z223.1/NFPA 54, CAN/CGA B149.1, and/or applicable provisions of local building codes.
2. This water heater is a direct vent appliance and is listed as a Category IV appliance with Underwriters Laboratories, Inc. VENT AND INTAKE AIR VENT

B. APPROVED MATERIALS FOR EXHAUST VENT AND INTAKE AIR VENT

Table 3-1

APPROVED PLASTIC EXHAUST VENTING MATERIAL		
MATERIAL	STANDARDS FOR INSTALLATION IN:	
	UNITED STATES	CANADA
PVC SCHEDULE 40 / 80	ANSI /ASTM D1785	ULC-S636
PVC -DWV	ANSI /ASTM D2665	ULC-S636
CPVC SCHEDULE 40 / 80	ANSI /ASTM F441	ULC-S636
*Note: Cellular Foam Core Pipe can only be used on INTAKE piping.		

Table 3-2

APPROVED PLASTIC INTAKE VENTING MATERIAL	
MATERIAL	STANDARDS FOR INSTALLATION IN:
	UNITED STATES AND CANADA
PVC SCHEDULE 40 / 80	ANSI /ASTM D1785
CPVC SCHEDULE 40 / 80	ANSI /ASTM F441
PVC DWV	ANSI /ASTM D2665
PVC-CELLULAR FOAM CORE*	U.L. LISTED
*Note: Cellular Foam Core Pipe can only be used on INTAKE piping.	

Table 3-3

APPROVED PLASTIC CONDENSATE PIPING MATERIAL	
MATERIAL	STANDARDS FOR INSTALLATION IN:
	UNITED STATES AND CANADA
PVC SCHEDULE 40 / 80	ANSI /ASTM D1785

Table 3-4

APPROVED PIPE CEMENT AND PRIMER FOR PLASTIC PIPE		
MATERIAL	STANDARDS FOR INSTALLATION IN:	
	UNITED STATES	CANADA
CPVC	ANSI/ASTM F493	ULC-S636 approved primer and adhesive system, for ULC-S636 pipe and fittings
PVC	ANSI/ASTM D2564	

⚠ WARNING

Do not use Foam Core Pipe in any portion of the exhaust piping from this water heater. Use of Foam Core Pipe may result in severe personal injury, death, or substantial property damage.

C. EXHAUST VENT AND INTAKE AIR VENT PIPE LOCATION

1. Determine exhaust vent location:

⚠ WARNING

Both exhaust and intake air vents must exit from the same side of the building to assure correct appliance operation.

- a. The vent piping for this water heater is approved for zero clearance to combustible construction.
- b. See illustration within this section of clearances for location of exit terminals of direct-vent venting systems.
- c. This water heater vent system shall terminate at least 3 feet (0.9 m) above any forced air intake located within 10 ft (3 m). Note: this does not apply to the combustion air intake of this direct-vent appliance.
- d. Provide a minimum of 1 foot distance from any door, operable window, or gravity intake into any building.
- e. Provide a minimum of 1 foot clearance from the bottom of the exhaust above the expected snow accumulation level. Snow removal may be necessary to maintain clearance.
- f. Provide 4 feet horizontal clearance from electrical meters, gas meters, gas regulators, relief equipment, exhaust fans and inlets. In no case shall the exit terminal be above or below the aforementioned equipment unless the 4 foot horizontal distance is maintained.
- g. When adjacent to a public walkway, locate exit terminal at least 7 feet above grade.
- h. Do not locate the exhaust directly under roof overhangs to prevent icicles from forming.

- i. Provide 4 feet clearance from the inside corner of vertical walls, chimneys, etc., as well as horizontal corners created by roof overhangs.

2. Determine air intake vent location.

- a. Provide 1 foot clearance from the bottom of the intake air vent and the level of maximum snow accumulation. Snow removal may be necessary to maintain clearances.
- b. Do not locate intake air vent in a parking area where machinery may damage the pipe.

- c. When venting with a two pipe system, maximum distance between intake air vent and exhaust vent is 6 feet (1.8 m). Minimum distance between exhaust vent and intake air vent on single water heater is 8" (0.2 m) center-to-center. Minimum distance between exhaust vents and intake air vents on multiple water heaters is 8" (0.2 m) center-to-center.
- d. You must place support brackets on vent piping. The first bracket must be within 1 foot of the appliance and the balance at 4 foot intervals on the vent pipe.

Location of exit terminals of mechanical draft and direct-vent venting systems.
 (Reference: National Fuel Gas Code ANSI Z223.1/NFPA 54 2002). In Canada, refer to CAN/CSA B149.1 for vent terminal location

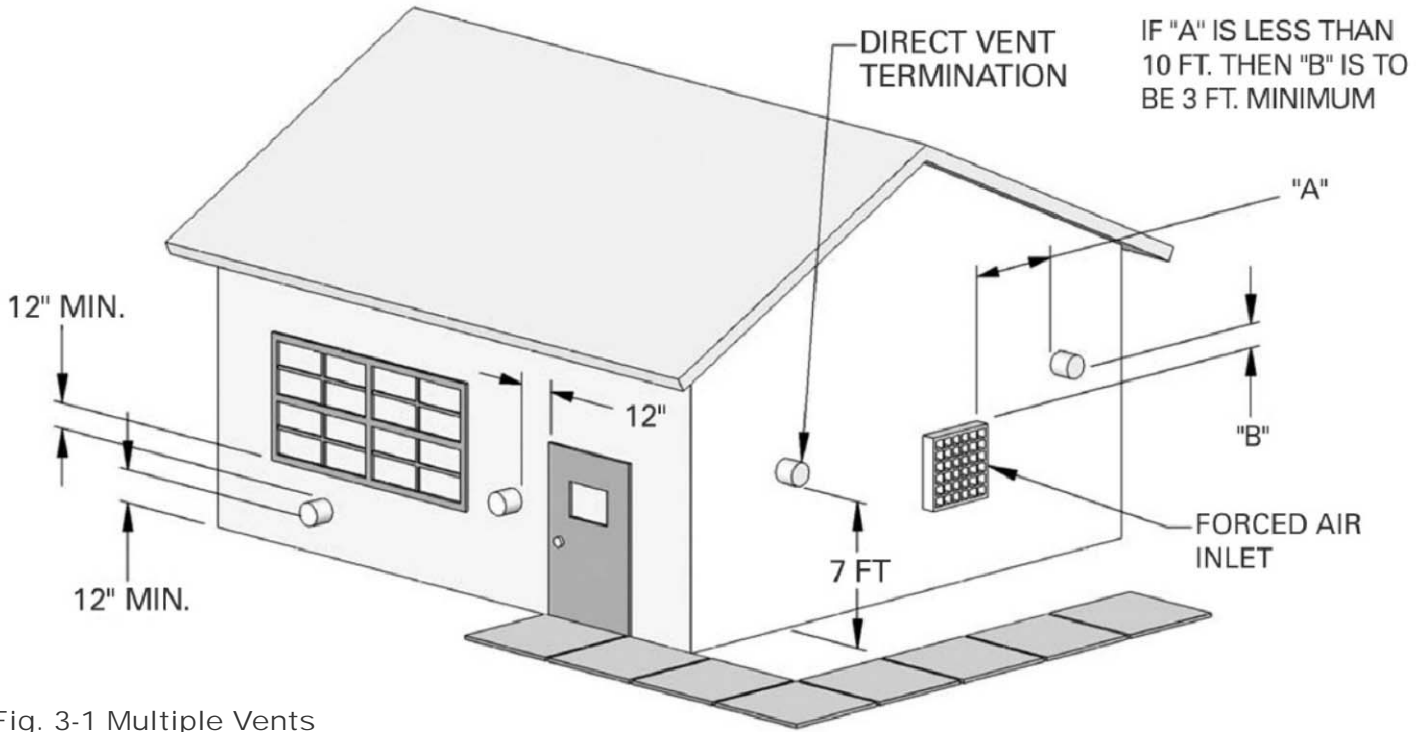

Fig. 3-1 Multiple Vents

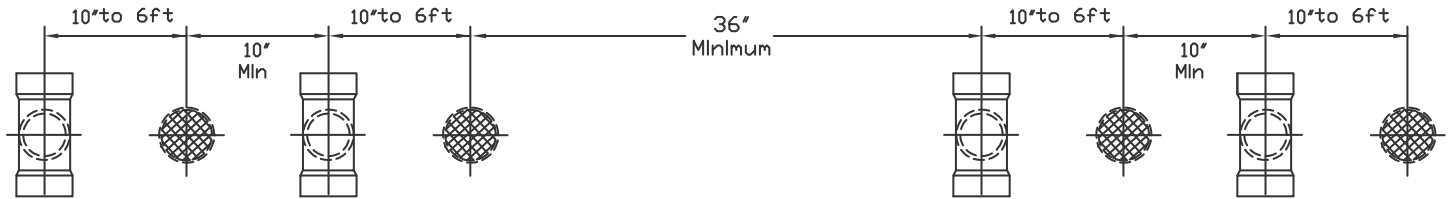

Fig. 3-2 Multiple Vent Spacing*

*Note: Exhaust must extend 1 foot. There should be no more than 2 vents and 2 intakes then a space of 36" to the next set of vents.
 *Note: There must be a minimum of 36" spacing between every 2 kit grouping.

Multiple Series Vents

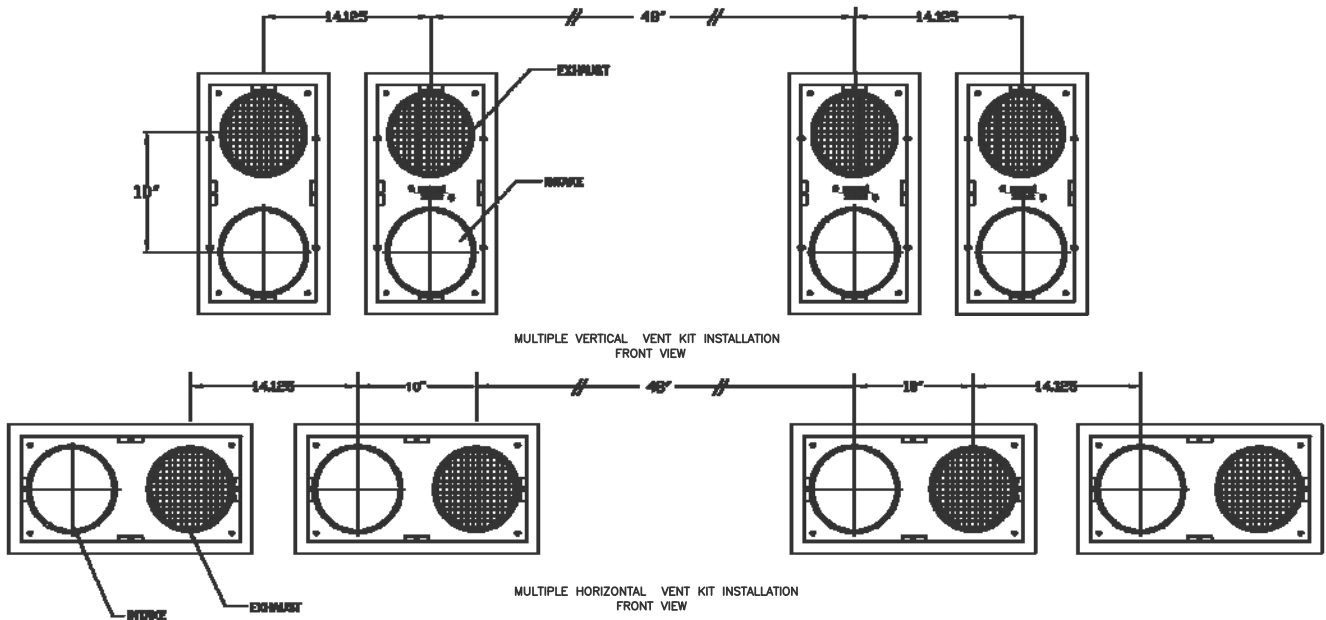

Fig. 3-3 Multiple Stainless Steel Horizontal Vent Kit Installation – Front View

D. EXHAUST VENT AND INTAKE AIR VENT SIZING

- The exhaust and intake vent size is 3" for all SE199's.
- The total combined equivalent length of exhaust vent and intake air pipe should not exceed 85 feet.
 - The equivalent length of elbows, tees, and other fittings are listed in the Friction Loss Table 3-5.

Table 3-5

FRICTION LOSS EQUIVALENT IN PIPING AND FITTINGS		
FITTINGS OR PIPING	EQUIVALENT FEET	
	3" (7.6 cm)	4" (10 cm)
90 DEGREE ELBOW*	5' (1.5 m)	3' (.92 m)
45 DEGREE ELBOW	3' (.92 m)	1' (.31 m)
COUPLING	0'	0'
AIR INLET TEE	0'	0'
STRAIGHT PIPE	1' (.31 m)	1' (.31 m)
CONCENTRIC VENT KIT SP12161	3' (.92 m)	N/A
V1100 3" VENT KIT SP12162	1' (.31 m)	N/A

*Friction loss for long radius elbow is 1 foot less

- For example: If the exhaust vent has two 90° elbows and 10 feet of PVC pipe we will calculate:

$$\text{Exhaust Vent Pipe Equivalent Length} = (2 \times 5) + 10 = 20 \text{ feet} \\ (.61 \text{ m} \times 1.5 \text{ m}) + 3 \text{ m} = 6.1 \text{ m}$$

Further, if the intake air vent pipe has two 90° elbows, one 45° elbow and 10 feet of PVC pipe, the following calculation applies:

$$\text{Intake Air Vent Pipe Equivalent Length} = (2 \times 5) + 3 + 10 = 23 \text{ feet} \\ (.61 \text{ m} \times 1.5 \text{ m}) + .92 \text{ m} + 3 \text{ m} = 7 \text{ m}$$

Finally, if a concentric vent kit is used we find:

$$\text{Total Combined Equivalent Length} = 20 + 23 + 3 = 46 \text{ feet} \\ .61 \text{ m} + 7 \text{ m} + .92 \text{ m} = 14 \text{ m}$$

Therefore, the total combined equivalent length is 46 feet which is well below the maximum of 85 feet.

- The intake air vent pipe and the exhaust vent are intended to penetrate the same wall or roof of the building.
 - Effort should be made to keep a minimum difference in equivalent length between the intake air vent pipe and the exhaust vent.
- The minimum combined equivalent length is 16 equivalent feet.

E. LONGER VENT RUNS

- The maximum combined equivalent length can be extended by increasing the diameter of both exhaust vent and intake air vent pipe equally. However, the transitions should begin a minimum of 15 equivalent feet from the water heater.
 - The maximum equivalent length for the increased diameter vent pipes is 125 feet.
 - Transitions should always be made in vertical sections of pipe to prevent the condensate from pooling in the vent pipe.

Table 3-6: Vent Run Transition

Vent Connection	Reducing Coupling	Vent Transition
3" (7.6 cm)	4" x 3" (10 cm x 7.6 cm)	4" (10 cm)

- If the transition occurs at a distance greater than 15 equivalent feet from the water heater, the maximum equivalent length will be reduced. See Table 3-7.

Table 3-7: Vent Termination Kits

Transition Point (ft from water heater)	TEL of Standard 2" Vent Pipe (ft)	TEL of Oversized 2", 3" or 4" Vent Pipe (ft)	Maximum TEL of all Vent Pipe (ft)
15 (4.58 m)	30 (9.1 m)	95 (29 m)	125 (38 m)
20 (6 m)	40 (12.2 m)	77-1/2 (23.6 m)	117-1/2 (35.9 m)
25 (7.6 m)	50 (15.2 m)	60-1/2 (18.4 m)	110-1/2 (33.7 m)
30 (9.1 m)	60 (18.2 m)	43 (13.1 m)	103 (31.4 m)
35 (10.7 m)	70 (21.3 m)	26 (7.92 m)	96 (29.2 m)
40 (12.2 m)	80 (24.3 m)	8-1/2 (2.6 m)	88-1/2 (27 m)
None	85 (27 m)	0	85 (26 m)

TEL = Total Equivalent Length

F. EXHAUST VENT AND INTAKE AIR PIPE INSTALLATION

- Use only solid PVC or CPVC for exhaust vent pipe. FOAM CORE PIPING, as well as PVC and CPVC, can be used for the intake vent pipe. Refer to chart Section 3B, Page 11.
- Remove all burrs and debris from joints and fittings.
- All joints must be properly cleaned, primed, and cemented. Use only cement and primer approved for use with the pipe material. Cement must conform to ASTM D2564 for PVC and ASTM F493 for CPVC pipe.

WARNING

All joints of positive pressure vent systems must be sealed completely to prevent leakage of flue products into the living space.

4. Horizontal lengths of exhaust vent must slope back towards the water heater not less than ¼" per foot to allow condensate to drain from the vent pipe. If the exhaust pipe must be piped around an obstacle that results in the creation of a low point, condensate will collect in this low point and form a blockage. This condensate must be drained away using a field-installed condensate drain assembly as shown. (See page 19)
5. All piping must be fully supported. Use pipe hangers at a minimum of 4 foot (1.2m) intervals to prevent sagging of the pipe where condensate may form.
6. Do not use the water heater to support any piping.
7. A screened straight coupling is provided with the water heater for use as an outside exhaust termination.

COMBUSTION SETTINGS HIGH FIRING RATES AND LOW FIRING RATES ON ALL MODELS				
	Natural Gas		Propane LP	
	low	high	low	high
Carbon Monoxide (CO%)	0–10 ppm	0 ppm–20 ppm	0–10 ppm	0 ppm–20 ppm
Carbon Dioxide (CO ₂ %)	8½% – 9½%	8½% – 9½%	9½% – 10½%	9½% – 10½%

FAN SPEED			
BTU	IGNITION	MIN	MAX
199,000	3000	2000	8500

G. VERY IMPORTANT SET-UP INSTRUCTIONS!

IF YOU HAVE A COMBUSTION ANALYZER, THE FOLLOWING RATINGS WILL BE **VERY HELPFUL** IN SETTING UP YOUR SUPER-E SP:

H. CONCENTRIC VENT

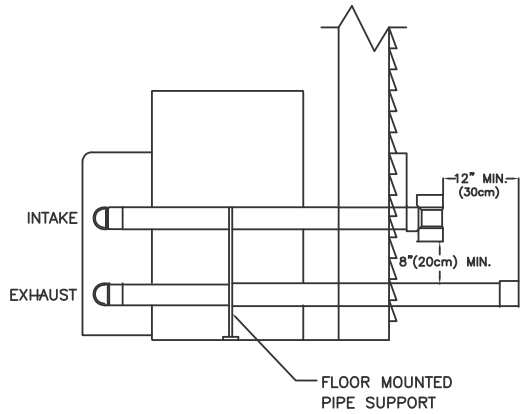

FIGURE 1
SIDE VENTING
SIDE VIEW

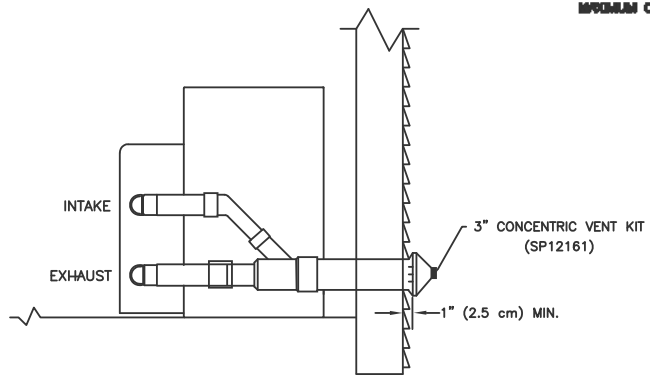

FIGURE 2
SIDE VENTING
SIDE VIEW

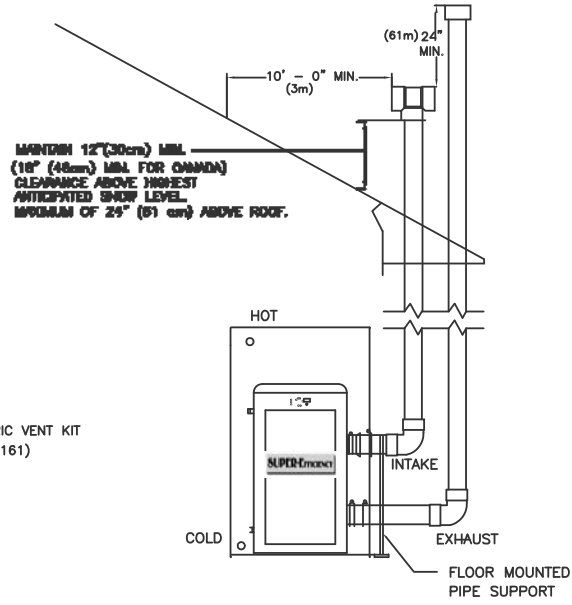

FIGURE 3
VERTICAL ROOF VENTING
FRONT VIEW

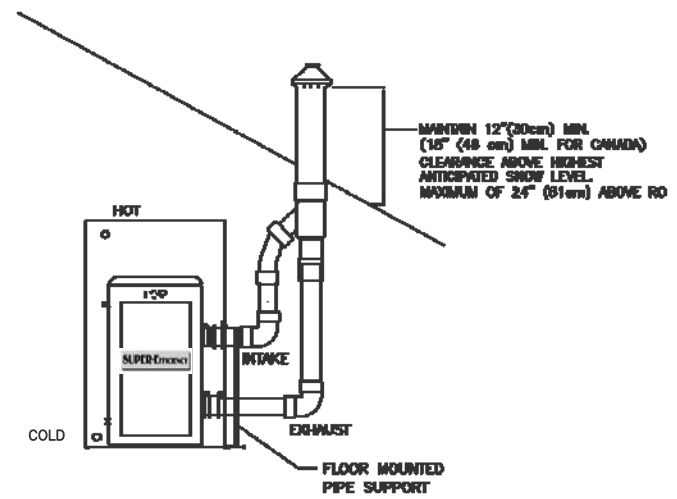

FIGURE 4
VERTICAL ROOF VENTING W/CONCENTRIC VENT KIT
(SP12161, 3 IN. - FRONT VIEW)

16

Note:

Spacing for multiple series of concentric vents should be the same as Multiple Vertical Vent in Fig. 3-3, P. 13.

3. Turn on gas shutoff valve (located inside of the down near burner) so that the handle is aligned with the gas pipe. If the handle will not turn by hand, don't try to repair it, call a qualified service technician. Force or attempted repair may result in a fire or explosion.
4. Do not use this appliance if any part has been under water. Immediately call a qualified service technician to inspect the appliance and to replace any part of the control system and any gas control which has been under water.
5. The Super-E SP shall be installed so the gas ignition system components are protected from water (dripping, spraying, rain, etc.) during appliance operation and service (circulator replacement, condensate trap, control replacement, etc.)

D. OPERATING INSTRUCTIONS

If you smell gas, **STOP**. Follow listed safety instructions above. If you do not smell gas, follow the next steps.

1. Turn on all electric power to appliance. Make sure tank is full with cold water and purge all piping. To assure adequate purging, open all hot water faucets.
2. Adjust the temperature setpoint of the appliance if desired. The factory default setting is 119° (48°C). If changes are necessary follow "Overall Appliance and Control Operation" in this section.
3. If the appliance fails to start, refer to the Troubleshooting section in the back of this manual.

WARNING

When this water heater is supplying general purpose hot water requirements for individuals, a thermostatically controlled mixing valve for reducing point of use water temperature is recommended. Contact a licensed plumber or the local plumbing authority for further instructions.

The three digit LED display will illustrate actual water temperature within the tank under normal operating conditions. However, this display is also used to indicate the temperature set point when in the programming mode.

The controller has a temperature set point range of 70°F (21°C) to 159°F (70.5°C) (Booster models have a maximum set point of 180°F [82°C]), with a factory setting of 120°F (49°C).

NOTE: Power must be applied to the controller prior

CAUTION

In unusually dirty or dusty conditions, care must be taken to keep appliance door in place. Failure to do so VOIDS WARRANTY!

to any programming operations.

The control system requires no periodic maintenance under normal conditions. However, in unusually dirty or dusty conditions, periodic vacuuming of the cover to maintain visibility of the display and indicators is recommended.

E. SHUTDOWN PROCEDURE

If the burner is operating, lower the set point value to 70°F (21°C) and wait for the burner to shut off. Continue to wait for the combustion blower to stop so all latent combustion gases are purged from the system. This should take a maximum of 40 to 90 seconds, then

WARNING

Should overheating occur or the gas supply fail to shut off, turn off the manual gas control valve to the appliance.

WARNING

DO NOT use this appliance if any part has been under water. Immediately call a qualified service technician to inspect the appliance and to replace the water heater if the control system or any gas control which has been under water.

disconnect the electrical supply. If the burner is not operating, disconnect the electrical supply.

F. PREVENT COMBUSTION AIR CONTAMINATION

Install intake air piping for the Super-E SP Water

WARNING

You must pipe outside air to the water heater air intake. Ensure that the intake air will not contain any of the contaminants below. Contaminated air will damage the water heater, resulting in possible severe personal injury, death or substantial property damage. For example, do not pipe intake air vent near a swimming pool. Also avoid areas subject to exhaust fumes from laundry facilities. These areas will always contain contaminants.

Heater as described in the Venting section. Do not terminate exhaust in locations that can allow contamination of intake air.

G. CORROSIVE CONTAMINANTS AND SOURCES

PRODUCTS TO AVOID
Spray cans containing fluorocarbons
Permanent wave solutions
Chlorinated waxes/cleaners
Chlorine-based swimming pool chemicals
Calcium chloride used for thawing
Sodium chloride used for water softening
Refrigerant leaks
Paint or varnish removers
Hydrochloric acid/muriatic acid
Cements and glues
Antistatic fabric softeners used in clothes dryers
Chlorine-type bleaches, detergents, and cleaning solvents found in household laundry rooms
Adhesives used to fasten building products and other similar products

AREAS LIKELY TO HAVE CONTAMINANTS
Dry cleaning/laundry areas and establishments
Swimming pools
Metal fabrication plants
Beauty shops
Refrigeration repair shops
Photo processing plants
Auto body shops
Plastic manufacturing plants
Furniture refinishing areas and establishments
New building construction
Remodeling areas
Garages and workshops

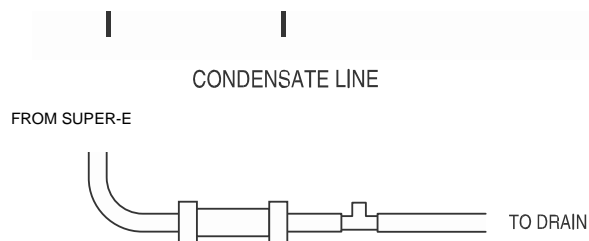

CONDENSATE LINE MUST BE PITCHED AT LEAST 1/4" (0.64cm 0.3m) PER FOOT TO PROPERLY DRAIN. IF THIS CANNOT BE DONE OR A VERY LONG LENGTH OF CONDENSATE HOSE IS USED YOU MUST INCREASE THE CONDENSATE HOSE TO A MINIMUM OF 1" (2.5cm) I.D. AND PLACE A TEE IN THE LINE AFTER THE CONDENSATE NEUTRALIZER TO PROPERLY REDUCE VACUUM LOCK IN THE DRAIN LINE.

⚠ DANGER

Do not install the Super-E SP into a common vent with any other appliance. This will cause flue gas spillage or appliance malfunction, resulting in possible severe personal injury, death or substantial property damage.

H. CONDENSATE

This is a condensing high efficiency appliance, therefore this unit has a condensate removal system. Condensate is nothing more than water vapor, derived from the combustion products, similar to an automobile when it is initially started. This condensate does have a low pH and should be treated with a condensate filter. This filter contains either lime crystals or marble crystals, which will neutralize the condensate. The outlet of the filter is sized for 5/8" (1.6 cm) ID (inside diameter) plastic tubing. It is very important that the condensate line is sloped away from and down to a suitable inside drain. If the condensate outlet on the Super-E SP is lower than the drain, you must use a condensate removal pump. It is also very important that the condensate line is not exposed to freezing temperatures, or any other type of blockage. Plastic tubing should be the only material used for the condensate line. Steel, brass, copper, or other metals will be subject to corrosion and deterioration. A second vent may be necessary to prevent condensate line vacuum lock if a long horizontal run is used. Also an increase to 1" (2.5 cm) tubing may be necessary.

NOTE: Always check local codes for proper evacuation of condensate.

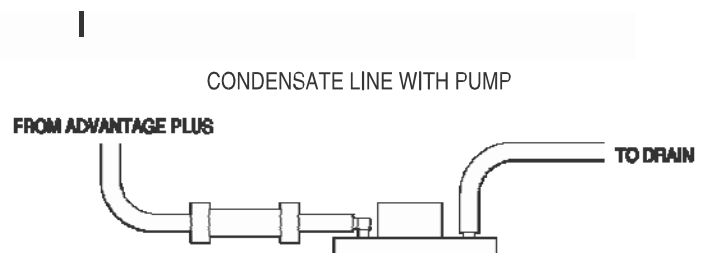

CONTACT YOUR LOCAL WHOLESALE PLUMBING SUPPLY STORE FOR MORE INFORMATION ON CONDENSATE NEUTRALIZERS AND PUMPS

Notes:

- CONDENSATE LINE MUST BE PITCHED AT LEAST 1/4" PER FOOT (0.64cm per 0.3m) TO PROPERLY DRAIN. IF THIS CANNOT BE DONE OR A VERY LONG LENGTH OF CONDENSATE HOSE IS USED YOU MUST INCREASE THE CONDENSATE HOSE TO A MINIMUM OF 1" (2.5CM) ID AND PLACE A TEE IN THE LINE AFTER THE CONDENSATE NEUTRALIZER TO PROPERLY REDUCE VACUUM LOCK IN THE DRAIN LINE.
- PLASTIC PIPE SHOULD BE THE ONLY MATERIAL USED FOR THE CONDENSATE LINE. STEEL, BRASS, COPPER OR OTHERS WILL BE SUBJECT TO CORROSION OR DETERIORATION.
- IT IS ALSO VERY IMPORTANT THAT THE CONDENSATE LINE IS NOT EXPOSED TO FREEZING TEMPERATURES, OR ANY OTHER TYPE OF BLOCKAGE.

PART 5: COMPONENTS OF THE SUPER-E SP

ITEM #	DESCRIPTION	PART #
1	GASKET - MOUNTING PLATE	7100P-026
2	SPARK ELECTRODE - NATURAL (W/GASKET, SCREWS)	7100P-029
2	SPARK ELECTRODE - LP (W/GASKET, SCREWS)	7100P-081
3	FLAME RECTIFICATION PROBE (W/GASKET, SCREWS)	7100P-024
4	BUNER GASKET - MOUNTING PLATE	7100P-152
5	BURNER (W/GASKET #4)	7100P-031
6	BURNER GASKET - BLOWER	G5020
7	GASKET - SIGHT GLASS	G5060
8	SIGHT GLASS (W/GASKETS)	G5021, G5060
9	COMBUSTION BLOWER (W/GASKET #6, ADAPTER PLATE, SCREWS)	7100P-015
10	AIR INTAKE ADAPTER - BLOWER SIDE	7500P-185
11	SWIRL PLATE	7100P-092
12	AIR INTAKE ADAPTER - VALVE SIDE	7500P-184
13	GAS VALVE (W/ AIR INTAKE ADAPTER, SWIRL PLATE, SCREWS)	7000P-863
14	BLOCKED VENT PRESSURE SWITCH	7250-150
15	OVER TEMPERATURE SWITCH	T1500
16	2" FLEXIBLE HOSE - AIR INTAKE	7500-189
17	926 CONTROL BOARD - 160°F, 199KBTU	7350P-008
18	926 DISPLAY BOARD (W/RIBBON CABLE)	7350P-009
	LOW VOLTAGE WIRING HARNESS (ATTACHED TO CONTROL BOARD - NOT SHOWN)	S7100-117
	120 VAC BLOWER WIRING HARNESS (ATTACHED TO CONTROL BOARD - NOT SHOWN)	S7100-118
19	TEMPERATURE PROBE	WHC1001-ECO-1
20	LOW WATER CUT-OFF SWITCH	7250P-150
	RELIEF VALVE	TP1400

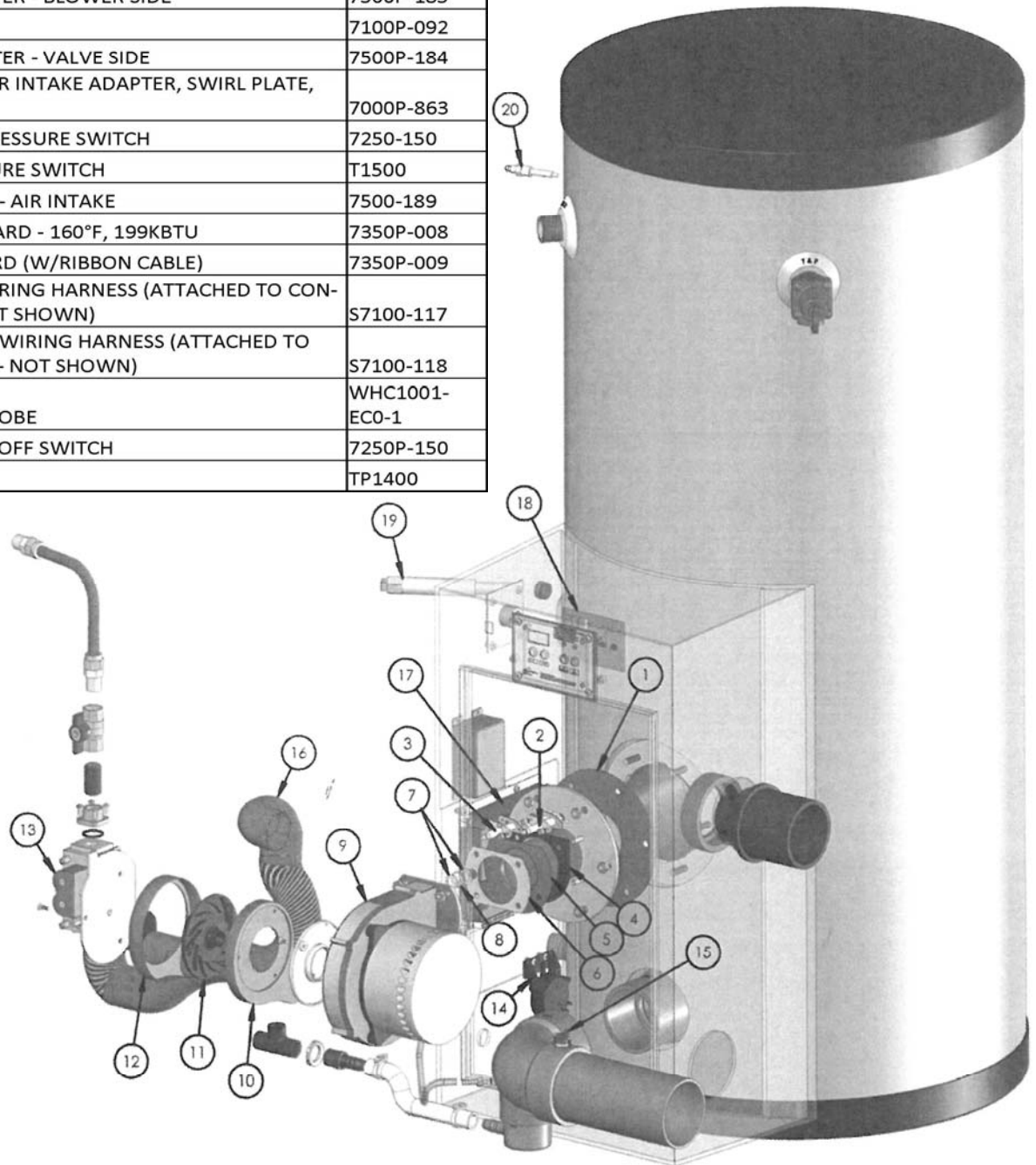

SUPER-E SP WIRING DIAGRAM

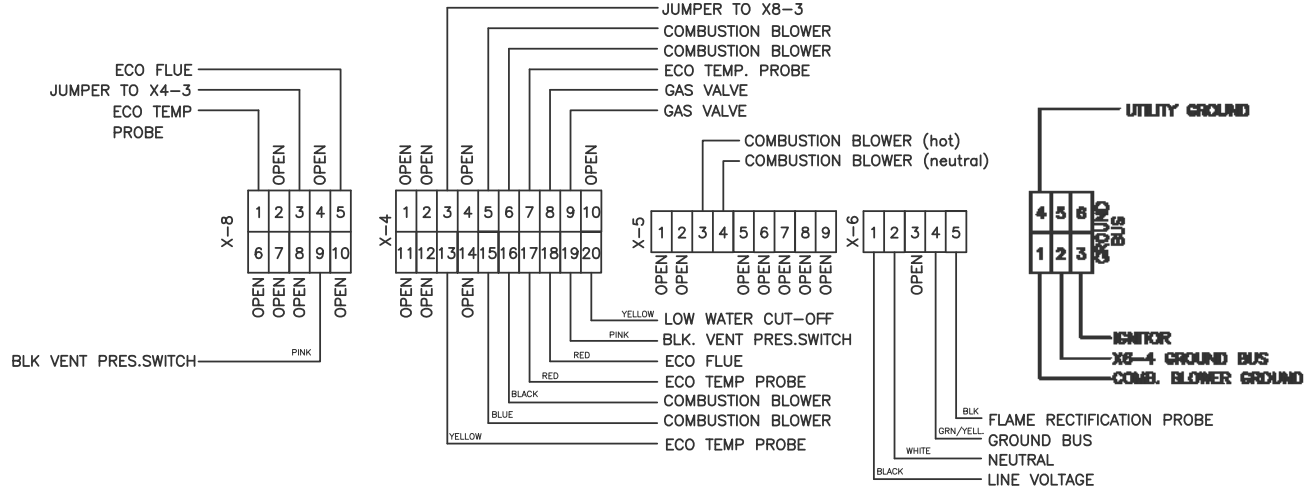
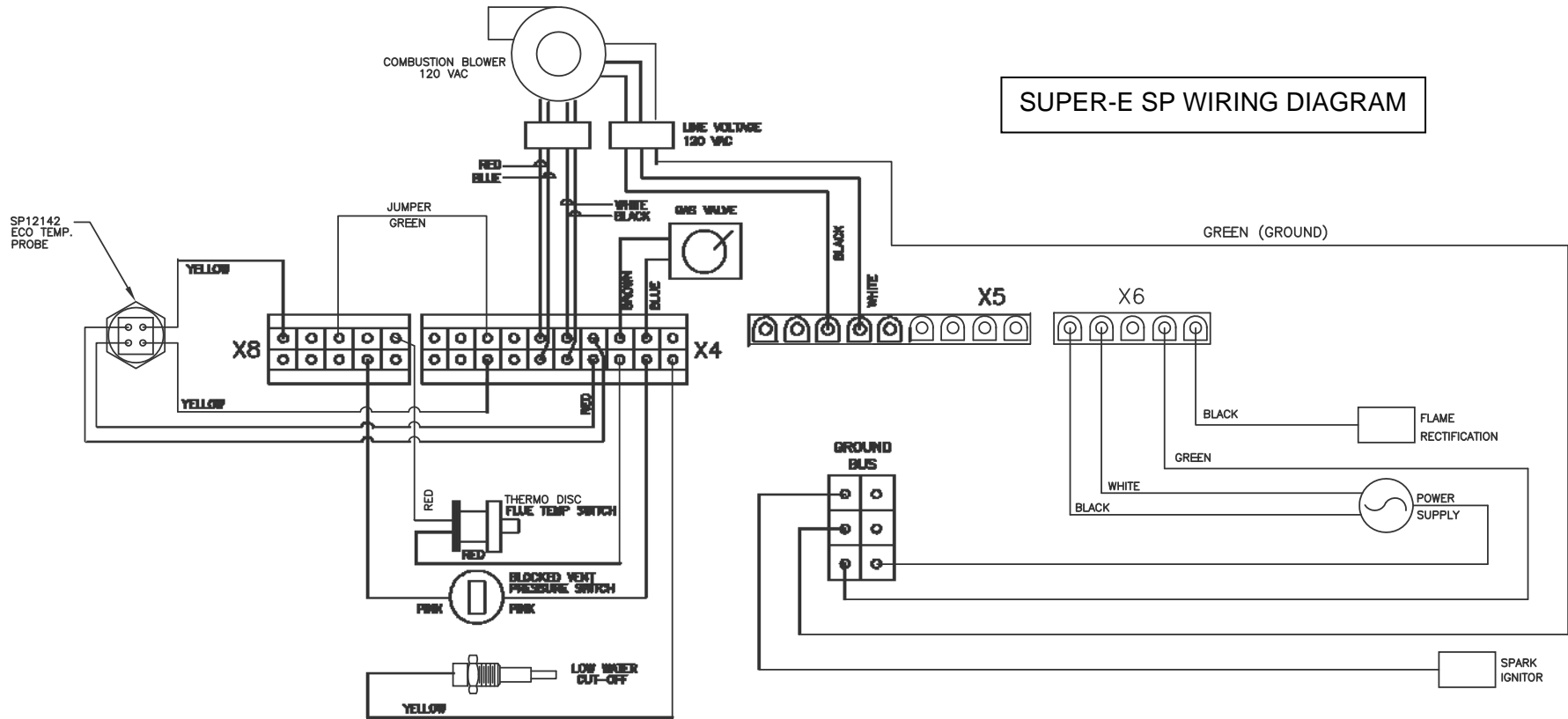

MOST COMMON SUPER-E SP INSTALLATION CONCERNS

VENTING:

VENT LENGTH TOO LONG - OVER 85' (26m)
VENTING NOT PITCHED PROPERLY - CONDENSATE BUILD UP IN VENT
EXHAUST GAS RE-CIRCULATION - VENT TERMINALS NOT USED, WRONG FITTINGS USED, SIGHT PROBLEMS
BUSH IN FRONT OF VENT TERMINAL
INSIDE CORNER OF BUILDING FOR VENT LOCATION
OVERHANG WITH VENT UNDERNEATH
COMPOUND ROOF PITCH, OR ABOVE ROOF FIRE WALL
ADDITIONAL FITTINGS INSTALLED INTO TERMINALS
VENT SIZED FROM 3" TO 4" BY USING BUSHINGS - INSTEAD OF REDUCING COUPLING OR REDUCING ELBOW
VENT CHANGED FROM 3" TO 4" - WITHOUT GOING REQUIRED 15' (4.6m) ON BOTH INTAKE AND EXHAUST
VENTING NOT CLEANED AND GLUED TOGETHER FOR PRESSURE TIGHT JOINTS
INTAKE AIR CONTAINING EXHAUST FROM ANOTHER VENT OR APPLIANCE

GAS SUPPLY:

GAS PRESSURE TOO LOW - NEED 3.5" WC (0.87 kPa) GAS PRESSURE UP TO 14" WC (3.5 kPa) GAS PRESSURE
GAS METER TOO LOW IN CAPACITY
GAS REGULATOR NOT SIZED PROPERLY - TOO LOW IN CAPACITY
GAS PIPE TOO SMALL - 3/4" MINIMUM GAS SUPPLY SIZE
GAS REGULATOR TOO CLOSE TO APPLIANCE - NEED 10' OF PIPE FOR EVERY 200,000 BTU'S PER HOUR
GAS REGULATOR WITH LONG VENT OR BLEED VENT ORIFICE - REGULATOR SLOW TO RESPOND
GAS METER RESTRICTION, OR IN NEED OF REPAIR/REPLACEMENT
GAS SUPPLY PRESSURE DROPS BELOW 3.5" WC (0.87 kPa) WHEN APPLIANCE FIRES

ELECTRICAL:

APPLIANCE NOT GROUNDED
ELECTRICAL POLARITY REVERSED - FLAME WILL LIGHT BUT GO BACK OUT IN 4-6 SECONDS VOLTAGE TOO LOW OR TOO HIGH
APPLIANCE CYCLES, BUT NO IGNITION - REMOVE ANY CORROSION FROM SPARK ELECTRODE AND RECTIFIER. CHECK GAP
SPACING ON SPARK ELECTRODE. SHOULD BE 1/4" SPACING.

PLUMBING: DIELECTRIC UNIONS INSTALLED - RUSTY WATER

CONDENSATE:

CONDENSATE LINE NOT PITCHED TO DRAIN
CONDENSATE LINE NOT DRAINING DUE TO LONG RUN WITHOUT VENT
CONDENSATE PUMP NOT WORKING
CONDENSATE TRAP PLUGGED

BURNER:

EXTREMELY LOUD BANG ON IGNITION - BURNER FAILED OR END CAP OFF
RED BURNER DECK AS SEEN THROUGH VIEW PORT - GAS VALVE NEEDS ADJUSTMENT

GAS VALVE:

PUFFING ON IGNITION - ADJUST GAS VALVE
LOUD POP ON IGNITION, THEN RUNNING SMOOTH - ADJUST GAS VALVE
HUFF AND PUFF DURING OPERATION - ADJUST GAS VALVE
RUNNING GREAT BUT INTERMITTENTLY HUFFING OR POPPING - CHECK FOR RE-CIRCULATION UNDER VENTING
IT IS IMPORTANT TO NOTE FOR MAINTENANCE PURPOSES: THE THREAD ON THE END OF THIS GAS VALVE AND NIPPLE IS A
LEFT HAND THREAD.

SEALING SUPER-E SP AS PER N.S.F. STANDARD NUMBER 5

TO SEAL THE BASE OF BOOSTER TO THE FLOOR TO
PREVENT SEE PAGE UNDERNEATH, PER N.S.F.
STANDARD #5 - APPLY A 3/8" BEAD OF RTV SILICONE
(AS SHOWN HERE), COMPLETELY AROUND TANK.

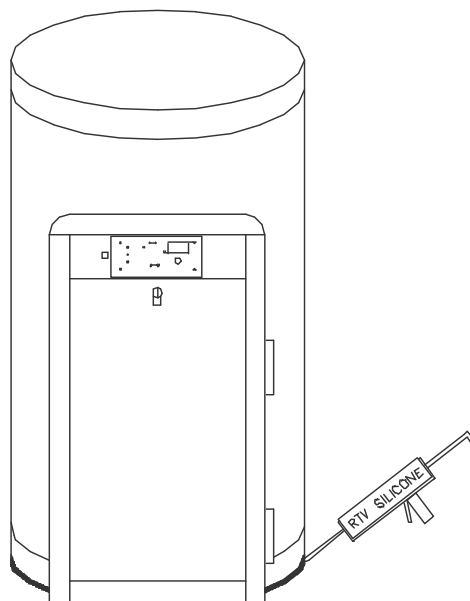

PART 6: TROUBLESHOOTING

Table 6-1: 926 Control Board Error Codes

Code	Description	Remedy
F00	High temperature switch limit exceeded (194°F [90°C])	<ol style="list-style-type: none"> 1. Try reset, if F00 repeats, create a demand for hot water (DANGER: use caution to prevent burn injury) If water is above 194°F (90°C) test upper and lower temperature sensor with an ohmmeter. (Refer to resistance chart, this section.) Replace bad sensor. If water is below 194° (90°C) test high temperature switch and wiring with ohmmeter. Switch should be closed at this point, if not, replace switch. 2. If unit did reset successfully, let the unit run and go into the status menu to check the upper and lower temperature sensor. If either reading displayed does not make sense, check appropriate sensor with ohmmeter. (Refer to resistance chart this section.) Replace bad sensor. Do an OHMs reading on both sensors to check continuity.
F01	Vent temperature limit exceeded	<ol style="list-style-type: none"> 1. Inspect all flue piping. If the flue is damaged or shows signs of overheating then repair or replace the flue parts as necessary before proceeding. 2. If the flue piping system is intact, not damaged and there is no sign of the flue overheating such as discoloration or melting, then push the red reset button on the flue switch. 3. Be sure the unit is connected to a water supply and full of water. 4. Push the RESET button on the unit control panel. The appliance should light. If the appliance lights proceed to step 5. If the appliance does not light and the display again begins to flash F01, inspect the wiring to the flue switch, repairing or replacing as necessary. If the wiring is intact, replace the flue switch using care to mount the new flue switch in the same position and mounting holes as the old one. If the display flashes a code other than F01, follow the troubleshooting guide for that code. 5. Observe operation for 5 minutes. Place the probe of an exhaust analyzer into the flue system within 6 feet of the unit appliance. The exhaust temperature should not rise above 190°F (88°C) after several minutes of operation. 6. If the flue temperature is below 190°F (88°C) and the appliance again goes into lockout displaying F01, replace the flue switch using care to mount the new flue switch in the same position and mounting holes as the old one. If the display flashes a code other than F01, follow the troubleshooting guide for that code. 7. If the flue temperature increases to over 190°F (88°C), Consult the Super-E SP factory for further assistance.
F02	Interrupted or shorted upper temperature sensor	Check the electrical connection to the appropriate temperature sensor, if connection is okay, replace bad sensor.
F03	Interrupted or shorted lower temperature sensor	
F05	Upper temperature sensor exceeds 194°F (90°C)	If water in tank is not greater than 190°F (88°C), check wiring and repair if faulty. If the wiring is okay, check appropriate sensor with ohmmeter and compare to reading in resistance chart. If reading does not agree with water temperature, replace bad sensor.
F06	Lower temperature sensor exceeds 194°F (90°C)	
F09	No flame detected – The unit will make three attempts at ignition before the control goes into this lockout condition. Will reset in 1 hour.	<ol style="list-style-type: none"> 1. Watch the igniter through the observation window provided. 2. If there is no spark, check the spark electrode for the proper ¼" (0.64 cm) gap. 3. Remove any corrosion from the spark electrode and flame rectifier probe. 4. If there is a spark but no flame, check the gas supply to the water heater. 5. If there is a flame, check the flame sensor. 6. Check any flue blockage or condensate blocks.
F10	Loss of Flame Signal – The unit will relight 4 times before the control goes into this lockout condition. Will reset in 1 hour.	<ol style="list-style-type: none"> 1. Monitor the gas pressure to the unit while in operation. 2. Assure that the flame is stable when lit. 3. Check to see if the green light on the display module is out while the water heater is running. 4. If the green light doesn't come on or goes off during operation check the flame signal on the status menu. 5. If the signal reads less than 1 microampere, clean the flame rectifier probe. 6. If the flame rectifier probe continues to read low, replace it.
F11	False Flame Signal – The water heater will lock out if it senses a flame signal when there should be none present.	<ol style="list-style-type: none"> 1. Turn the gas off to the unit at the service valve. 2. If the flame signal is still present replace the igniter. 3. If the flame signal is not present after turning off the gas supply, check the gas valve electrical connection. 4. If there is no power to the gas valve, remove the valve and check for obstruction in the valve seat or replace the gas valve. 5. Turn the gas on at the service valve after corrective action is taken.
F13	Combustion Fan Speed Incorrect – The water heater will lock out if it senses that the fan speed is less than 70% of expected rate for more than 60 seconds.	<ol style="list-style-type: none"> 1. Check the combustion air fan wiring. 2. Replace the combustion air fan. 3. Replace the control board.

NOTE: IF YOU REPLACE A PART TO REMEDY A FAULT, IT IS RECOMMENDED THAT YOU CYCLE THE UNIT AT LEAST THREE OR FOUR TIMES TO ASSURE THE FAULT HAS BEEN RESOLVED.

Table 6-2: Super-E SP Resistance Table for Supply Temperature Sensor

High/Low Temp. Sensor Temp.	Resistance (ohms)
32°F (0°C)	32550
41°F (5°C)	25340
50°F (10°C)	19870
59°F (15°C)	15700
68°F (20°C)	12490
77°F (25°C)	10000
86°F (30°C)	8059
95°F (35°C)	6535
104°F (40°C)	5330
113°F (45°C)	4372
122°F (50°C)	3605
131°F (55°C)	2989
140°F (60°C)	2490
149°F (65°C)	2084
158°F (70°C)	1753
167°F (75°C)	1481
176°F (80°C)	1256
185°F (85°C)	1070
194°F (90°C)	915
202°F (95°C)	786
212°F (100°C)	667

Table 6-3: 926 Control Board Error Codes

Code	Description	Duration	Corrective Action
E13	Combustion Fan Speed Low. The combustion air fan speed less than 70% of expected.	60 Sec.	<ol style="list-style-type: none"> 1. Check the combustion air fan wiring. 2. Replace the combustion air fan. 3. Replace the control board.
E14	Combustion Fan Speed High. The combustion air fan speed is more than 130% of expected.	60 Sec.	<ol style="list-style-type: none"> 1. Check the combustion air fan wiring. 2. Replace the combustion air fan. 3. Replace the control board.
LEO	Water level in tank is low	Until Corrected	<ol style="list-style-type: none"> 1. Be sure all air is bled from system. 2. Inspect low level switch and wiring for damage and repair as necessary.
FLU	Blocked Vent Pressure Switch Open	Until Corrected	<ol style="list-style-type: none"> 1. Assure that the vent is not blocked 2. Check the blocked vent pressure switch operation by applying a jumper. (If the switch is not functioning properly, replace it.)
LOU	24 VAC low	Until Corrected	<ol style="list-style-type: none"> 1. Check line voltage. Must be between 100-128 VAC. 2. If available, connect PC and using Super-E SP service software check the 24 VAC supply display in the lower left corner of the screen. The number displayed here must be greater than 128 and should be greater than 250. Use this as a troubleshooting guide as you follow the steps below. 3. Remove 10 pin Molex connector from customer connection board. If LOU code clears, then the problem is with external sensor wiring. Examine external sensor wiring for shorts to ground repairing as necessary. If LOU code is still present and the boiler is so equipped, disconnect high gas pressure switch, then low gas pressure switch, then UL 353 low water cutoff in this order one at a time to see if LOU code clears. Replace faulty part. Check low voltage wire harness in boiler for shorts to ground. 4. If LOU only occurs when burner tries to light, check gas valve for excessive current draw. 5. If LOU is present with the low voltage harness disconnected from the 926 control board, replace the 926 control board.

HOW TO GET YOUR SUPER-E SP SERVICED

⚠ WARNING

If the information in these instructions are not followed exactly, a fire or explosion may result causing property damage, personal injury or death.

⚠ FOR YOUR SAFETY!

- Do not store or use gasoline or other flammable vapors or liquids or other combustible materials in the vicinity of this or any other appliance. To do so may result in an explosion or fire
- WHAT TO DO IF YOU SMELL GAS
 - Do not try to light any appliance.
 - Do not touch any electrical switch; do not use any phone in your building.
 - Immediately call your gas supplier from a neighbor's phone. Follow the gas supplier's instructions.
- If you cannot reach your gas supplier, call the fire department.
- Do not return to your building until authorized by the gas supplier or fire department.
- Improper installation, adjustment, alteration, service or maintenance can cause injury, property damage or death. Refer to this manual. Installation and service must be performed by a qualified installer, service agency or gas supplier.

STEP I: CALL YOUR INSTALLATION AND SERVICE CONTRACTOR

Your installation and service contractor should have read the installation instructions, and should be capable of servicing the unit. Please contact them first. If the issue cannot be handled in this way, continue as follows.

STEP II: GATHER THE MODEL #, SERIAL #, AND DATE OF INSTALLATION

- a) The Model # of your unit: this will either be a SE199-80 (80 gallon) or SE199-119,
- b) The Serial # of your unit: this will be located on the label just to the left of the control box.
- c) The installation date of your unit: you can determine this from your contractor or installation invoice. If NATCO has received a warranty registration, we will be able to determine this for you.

STEP IV: CALL NATCO TECHNICAL SUPPORT

- a) Call NATCO Technical Support during normal business hours (Monday through Friday, 8:30am to 5:00 pm).
- b) Email NATCO Technical Support at technical@nationalcombustion.com. Have all of the above information available. We will not be able to help you without model numbers and serial numbers.

STEP V: EMAIL US FOR EMERGENCY SERVICE DURING NON-BUSINESS HOURS

- c) Email emergency@nationalcombustion.com and someone will get back to you as soon as possible. Have all of the above information available. We will not be able to help you without model numbers and serial numbers.



National Combustion Co., Inc.

104-11 180th Street
Jamaica, NY 11433
Ph: 718-291-8400
Fx: 718-291-6870

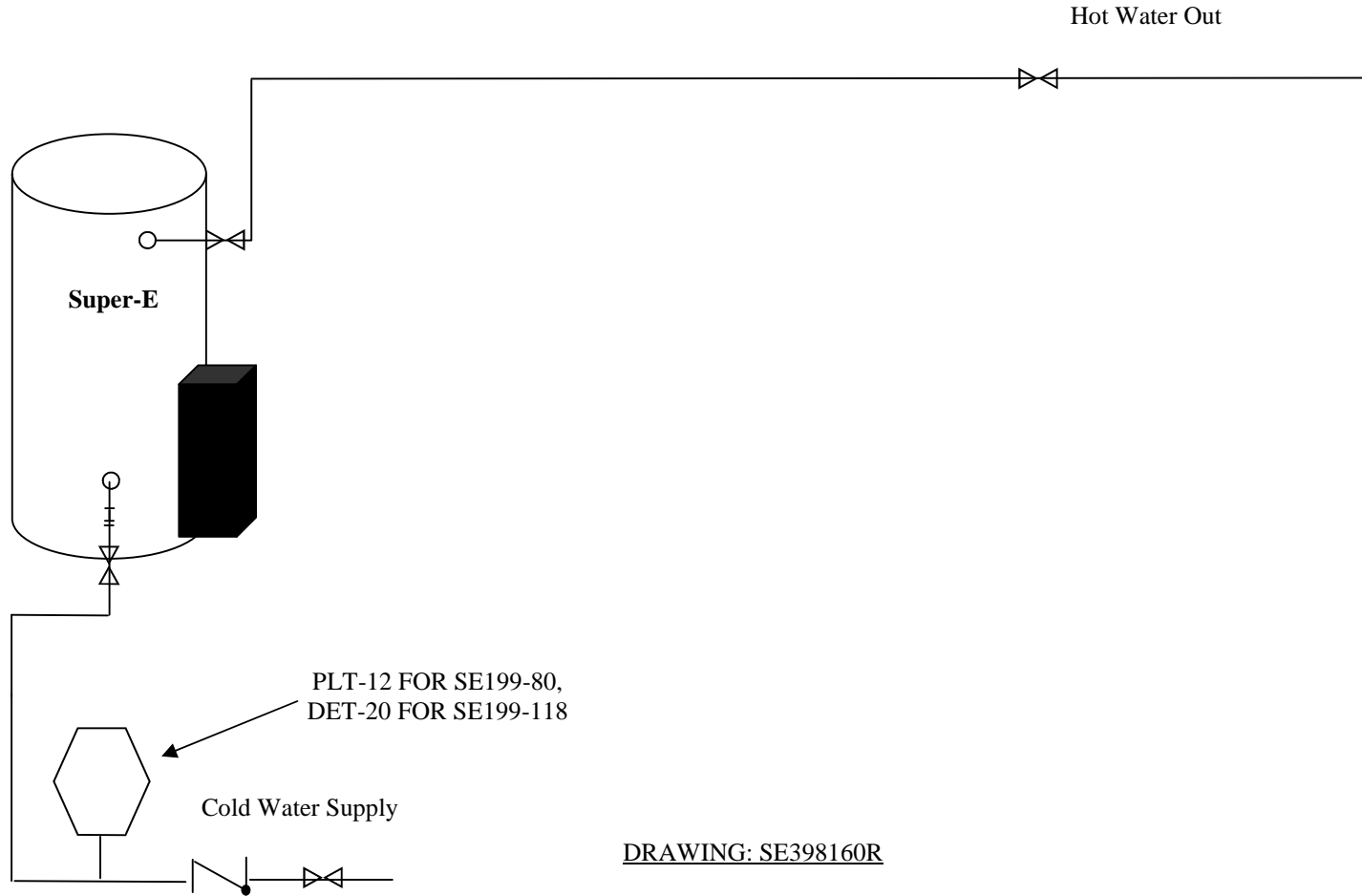

DRAWING: SE398160R

1 80 or 119 Gallon Super-E's w/o recirculation line

Notes:

1. This drawing shows suggested piping configuration. Check local codes and ordinances for additional requirements.
2. Minimum 1-1/2" cold water supply & hot water to store lines recommended.
3. Back flow preventer may be required. Check local codes.
4. Thermal expansion tank is required.
5. Additional ball-valves, drain valves, and unions may be used for ease of maintenance.



National Combustion Co., Inc.
104-11 180th Street
Jamaica, NY 11433
Ph: 718-291-8400
Fx: 718-291-6870

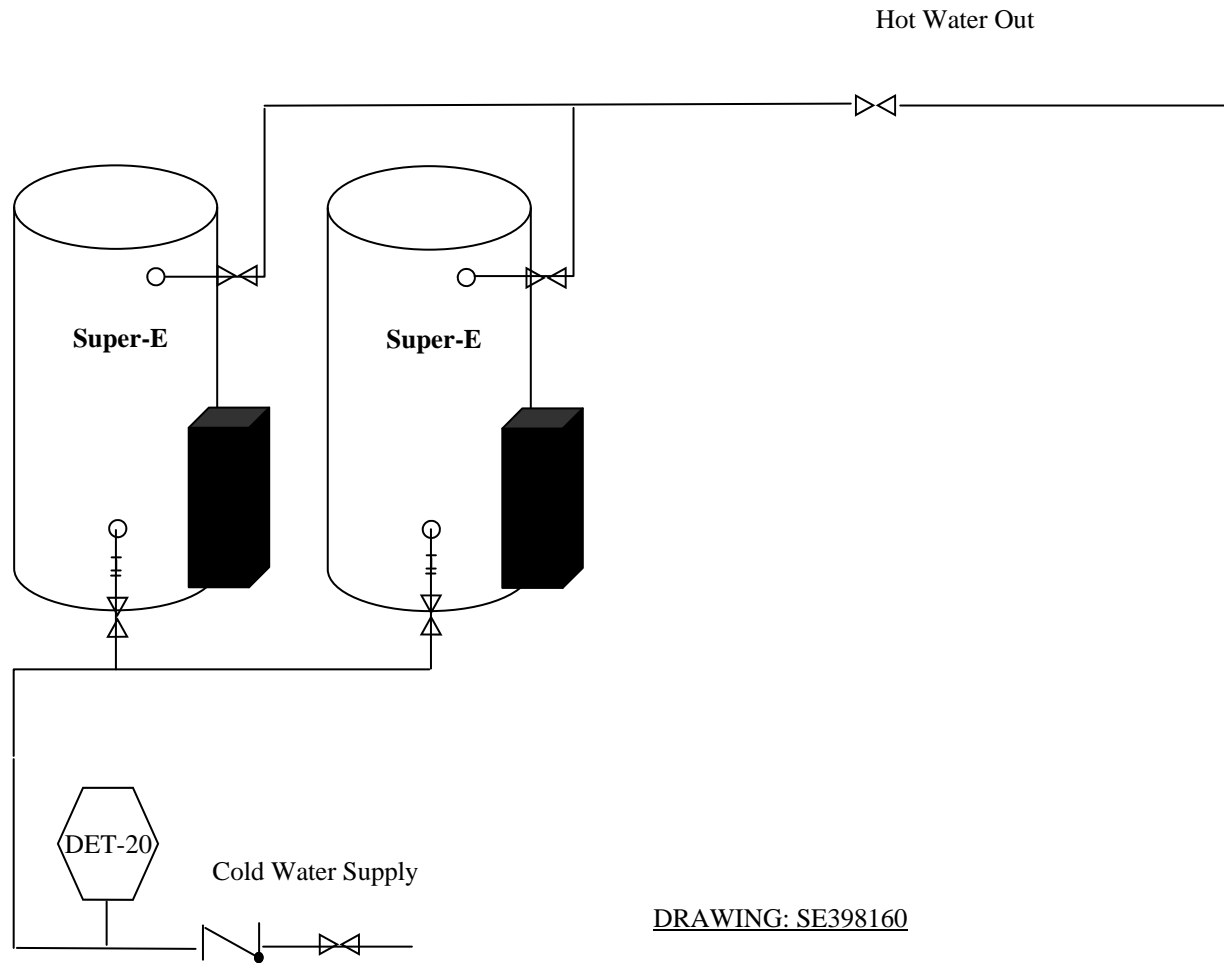

DRAWING: SE398160

2 80 or 119 Gallon Super-E's w/o recirculation line

Notes:

1. This drawing shows suggested piping configuration. Check local codes and ordinances for additional requirements.
2. Minimum 1-1/2" pipe size throughout is recommended.
3. Back flow preventer may be required. Check local codes.
4. Thermal expansion tank is required. NATCO suggests using 1 Watts DET-20 expansion tanks.
5. Additional ball-valves, drain valves, and unions may be used for ease of maintenance.

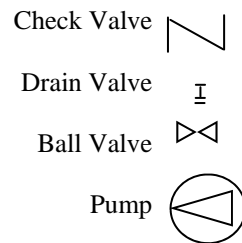



National Combustion Co., Inc.
 104-11 180th Street
 Jamaica, NY 11433
 Ph: 718-291-8400
 Fx: 718-291-6870

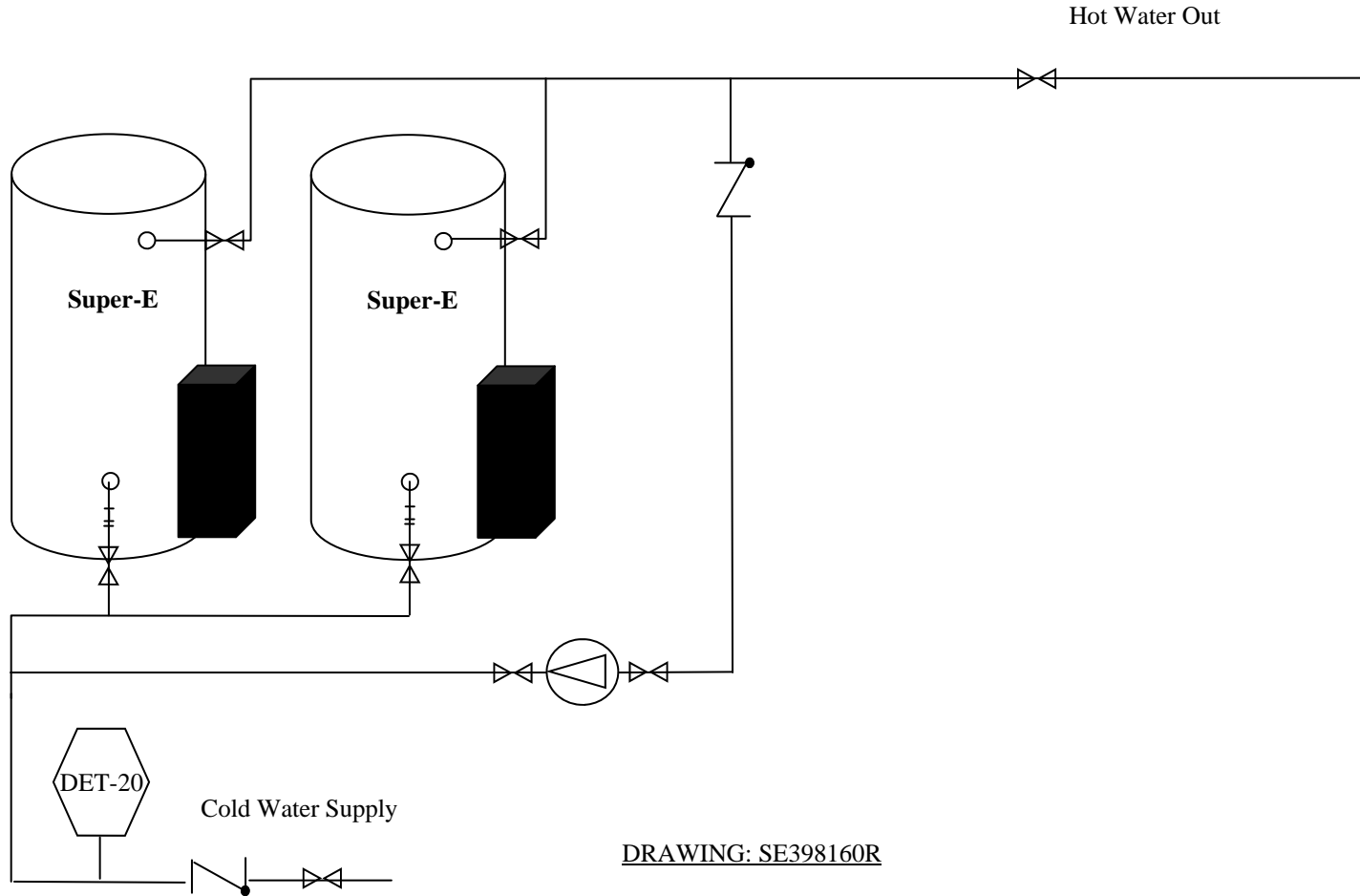

DRAWING: SE398160R

2 80 or 119 Gallon Super-E's w/ recirculation line

Notes:

1. This drawing shows suggested piping configuration. Check local codes and ordinances for additional requirements.
2. Minimum 2" cold water supply & hot water to store lines recommended.
3. Minimum 1" recirculation line is recommended. 2" Optimal.
4. Back flow preventer may be required. Check local codes.
5. Thermal expansion tank is required. NATCO suggests using 1 Watts DET-35 expansion tanks.
6. Additional ball-valves, drain valves, and unions may be used for ease of maintenance.

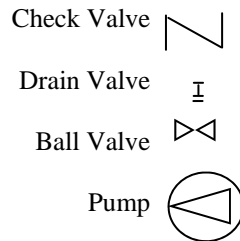

LIMITED WARRANTY
For National Combustion Co., Inc. Super-E Gas-Fired Water Heaters
GENERAL

This Limited Warranty is only available to the original owner of this water heater. It is not transferable. National Combustion warrants this Super-E water heater, and its component parts, to be free from defects in materials and workmanship, under normal use and service, for the Applicable Warranty period. At its option National Combustion will repair or replace the defective Super-E water heater, or defective component part(s), in accordance with the terms of this Limited Warranty, if it fails in normal use and service during the Applicable Warranty Period. Any replacement water heater or replacement component part(s) must be authorized by National Combustion. Replacement units will be warranted only for the unexpired portion of the original water heater's Applicable Warranty Period. Replacement parts will be warranted for 1 year.

EFFECTIVE DATE

The Effective date of warranty coverage (or the beginning of the Applicable Warranty Periods) is the date of original installation of the Super-E water heater, if properly documented. Otherwise, it is the date of manufacture of the Super-E water heater.

APPLICABLE WARRANTY PERIOD

The Super-E tank, including heat exchanger, is warranted for a total of 5 years from the Effective Date. Super-E parts, including blower motor, controls, spark assembly, sensors, etc. are warranted for 1 year from the Effective Date.

WARRANTY EXCLUSIONS

This Limited Warranty will not cover:

- a) Service trips to teach you how to install, use or maintain this Super-E water heater or to bring the Super-E water heater's installation into compliance with local building codes and regulations.
- b) Damages, malfunctions, or failures resulting from failure to install the Super-E water heater in accordance with applicable building codes/ordinances or good plumbing and electrical trade practices.
- c) Damages, malfunctions, or failures resulting from improper installation or failure to operate and maintain the Super-E water heater in accordance with the manufacturer's instructions provided.
- d) Performance problems caused by improper sizing of the Super-E water heater or the gas supply line, the venting connection, combustion air openings, electric service voltage, wiring, or fusing.
- e) Damages, malfunctions, or failures caused by improper conversion from natural gas to LP gas or LP gas to natural gas fuel source.
- f) Damages, malfunctions or failures caused by operating the Super-E water heater with modified, altered, or unapproved parts installed.
- g) Damages, malfunctions, or failures caused by abuse, accident, fire, flood, freeze, lightning, acts of God, and the like.
- h) Tank failures (leaks) caused by operating the Super-E water heater in a corrosive or contaminated atmosphere.
- i) Damages, malfunctions, or failures caused by operating the Super-E water heater with an empty, or partially empty, tank (also known as "dry firing").
- j) Damages, malfunctions, or failures caused by operating the Super-E unit at water temperatures exceeding the maximum setting of the operating, or high limit, control.
- k) Tank failures caused by operating the Super-E water heater when it is not supplied with potable water, free to circulate at all times.
- l) Damages, malfunctions, or failures caused by subjecting the tank to pressures, or firing rates, greater than those shown on the rating label.
- m) Damages, malfunctions, or failures resulting from the use of any attachment, including any energy saving device, not authorized by National Combustion.
- n) Super-E units installed outside the fifty states (and the District of Columbia) of the United States of America.
- o) Super-E commercial units moved from the original installation location.
- p) Super-E commercial units that have had their rating labels removed. A Super-E commercial water heater should not be operated if the rating label is removed.
- q) This water heater must be located in an area where leakage of the tank or water line connections and the combination temperature and pressure relief valve will not result in damage to the area adjacent to the water heater or to lower floors of the structure. When such locations cannot be avoided, a suitable drain pan, adequately drained, be installed under the water heater.

LABOR, SHIPPING AND PROCESSING COST

This Limited Warranty does not cover any labor expenses for service, repairs, reinstallation, permits, or removal and disposal of the failed Super-E water heater, or defective component part(s). All such expenses are your responsibility.

National Combustion Co., Inc. does not authorize, recommend, or receive any benefit from any claims processing or similar fees charged by other to process warranty claims for any Super-E water heater, or component part(s). National Combustion Co., Inc. will not reimburse any party for these, or any other, fees not specifically covered in this Limited Warranty document.

HOW TO OBTAIN WARRANTY CLAIM ASSISTANCE

Any claim for warranty assistance must be made promptly. First, determine if your Super-E water heater is within the Applicable Warranty Period. You can determine your Super-E's warranty status by obtaining the complete model number, the complete serial number and the installation date of your Super-E water heater by contacting National Combustion Co., Inc.'s Warranty Department (tel. no 718-291-8400) during normal business hours to determine if the Applicable Warranty Periods have expired.

If your Super-E water heater is within the Applicable Warranty Period, contact the plumber, or mechanical contractor, that installed it for assistance with the warranty repairs, or replacement, required. You may also select a plumber, or mechanical contractor from your local Yellow Pages to assist you. National Combustion's Technical Service Department are available to assist you (tel. no. 718-291-8400) in obtaining service or to answer your questions about the operation or repair of your Super-E commercial water heater during normal business hours. Be prepared to provide the plumber, or mechanical contractor, or National Combustion Co., Inc. technical service person you call with the complete model number, the complete serial number, and the date of installation of your Super-E water heater in addition to an explanation of your Super-E water heater problem.

If an exact replacement is not available, National Combustion Co., Inc. will provide you with the current model of your Super-E water heater, or component part(s), or a replacement unit with comparable operating features. If government regulations or industry certification or similar standards require the replacement Super-E water heater, or replacement component part(s), to have features not found in the defective Super-E commercial water heater, or the defective component part(s), you will be charged for the difference in price represented by those required features. If you pay the price difference for those required features and/or to upgrade the size and/or other features available on a replacement new Super-E water heater, you will also receive a complete new Limited Warranty (with the full Applicable Warranty Period) for the replacement new Super-E water heater.

DO NOT DESTROY, OR DISPOSE OF, ANY SUPER-E OR DEFECTIVE PART(S) WITHIN THE APPLICABLE WARRANTY PERIOD. NATIONAL COMBUSTION HOLDS THE RIGHT TO REQUIRE ANY SUPER-E UNIT OR COMPONENT PART(S) TO BE RETURNED (WITH ORIGINAL RATING LABEL AND COMPONENT PARTS INTACT) IN EXCHANGE FOR THE REPLACEMENT UNIT. Each defective component part within the applicable warranty period to be replaced must be returned to National Combustion Co., Inc. in exchange for the replacement component part.

Warranty compensation is subject to validation of applicable warranty period coverage by National Combustion Co., Inc. Claims Department personnel.

- To obtain warranty compensation for an "in-warranty" water heater failure, you must provide National Combustion Co., Inc., at the option of National Combustion Co., Inc., either (i) the failed Super-E unit (with rating label and all the component parts intact); the complete model number and the complete serial number of the Super-E that replaced the failed Super-E unit.; and, the date the original Super-E water heater failed, or (ii) the complete Super-E rating label, without which it should never be operated; the complete model number and the complete serial number of the Super-E that replaced the failed Super-E unit.; and, the date the original Super-E water heater failed.
- To receive warranty compensation for component parts within the applicable warranty period, you must provide National Combustion Co with: the defective component part; the complete model number and the complete serial number of the Super-E water heater from which the defective component part was removed; and, the date the defective part failed. You may also be required to provide documentary proof of the date of installation of the water heater from which the defective component part was removed – or the date of purchase of the component part (if it was purchased separately) – to establish the "in-warranty" status of the defective component part.

Warranty claim documentation should be mailed promptly to National Combustion Co., Inc., Warranty Dept., 104-11 180th Street, Jamaica, NY 111433.

EXCLUSIVE WARRANTY – LIMITATION OF LIABILITY

This Limited Warranty is the only Warranty for this unit given by National Combustion Co., Inc. No one is authorized to make any other warranties on behalf of National Combustion Co., Inc. ANY IMPLIED WARRANTIES, INCLUDING MERCHANTABILITY, OR FITNESS FOR A PARTICULAR PURPOSE, SHALL NOT EXTEND BEYOND THE APPLICABLE WARRANTY PERIODS SPECIFIED PREVIOUSLY. NATIONAL COMBUSTION CO., INC.'S SOLE LIABILITY, WITH RESPECT TO ANY DEFECT, SHALL BE AS SET FORTH IN THIS LIMITED WARRANTY, AND ANY CLAIMS FOR INCIDENTAL OR CONSEQUENTIAL DAMAGES (INCLUDING DAMAGE FROM WATER LEAKAGE) ARE EXCLUDED. Some states do not allow limitations on how long an implied warranty lasts, or for the exclusion of incidental or consequential damages, so the above limitations may not apply to you.

This Limited Warranty gives you specific legal rights, and you may also have other rights, which vary from state to state.

We suggest you immediately complete the information on the attached warranty information form in the event warranty service is needed. Reasonable proof of the date of installation of your Super-E water heater may be required to establish its applicable warranty period. Otherwise the Effective Date of the Limited Warranty will be the date of manufacture of the Super-E water heater plus ninety (90) days.

DO NOT RETURN THIS DOCUMENT TO NATIONAL COMBUSTION CO., INC.
KEEP IT WITH YOUR SUPER-E WATER HEATER OR BUSINESS RECORDS.

Name of Owner/Business Location
Where Unit is installed: _____

Super-E Water Heater Installation Address: _____

Date Super-E Water Heater was Installed: _____

Name of Plumber/Mechanical Contractor – Installer: _____

Plumber/Mechanical Contractor – Installer's Address: _____

Complete Model # of the Super-E: _____

Complete Serial Number of the Super-E: _____

**CERTIFICATE
OF LIMITED
WARRANTY**



SUPER-E

GAS-FIRED WATER HEATER