

To Building DHW Supply

*Suggested Pipe Sizing for Fire-Coil
to storage tank connections*



Heater Model	Pipe Size (NPS)
PFC 175-400	1-1/2"

National Combustion Co., Inc.
 104-11 180th Street
 Jamaica, NY 11433
 Ph: 718-291-8400
 Fx: 718-291-6870

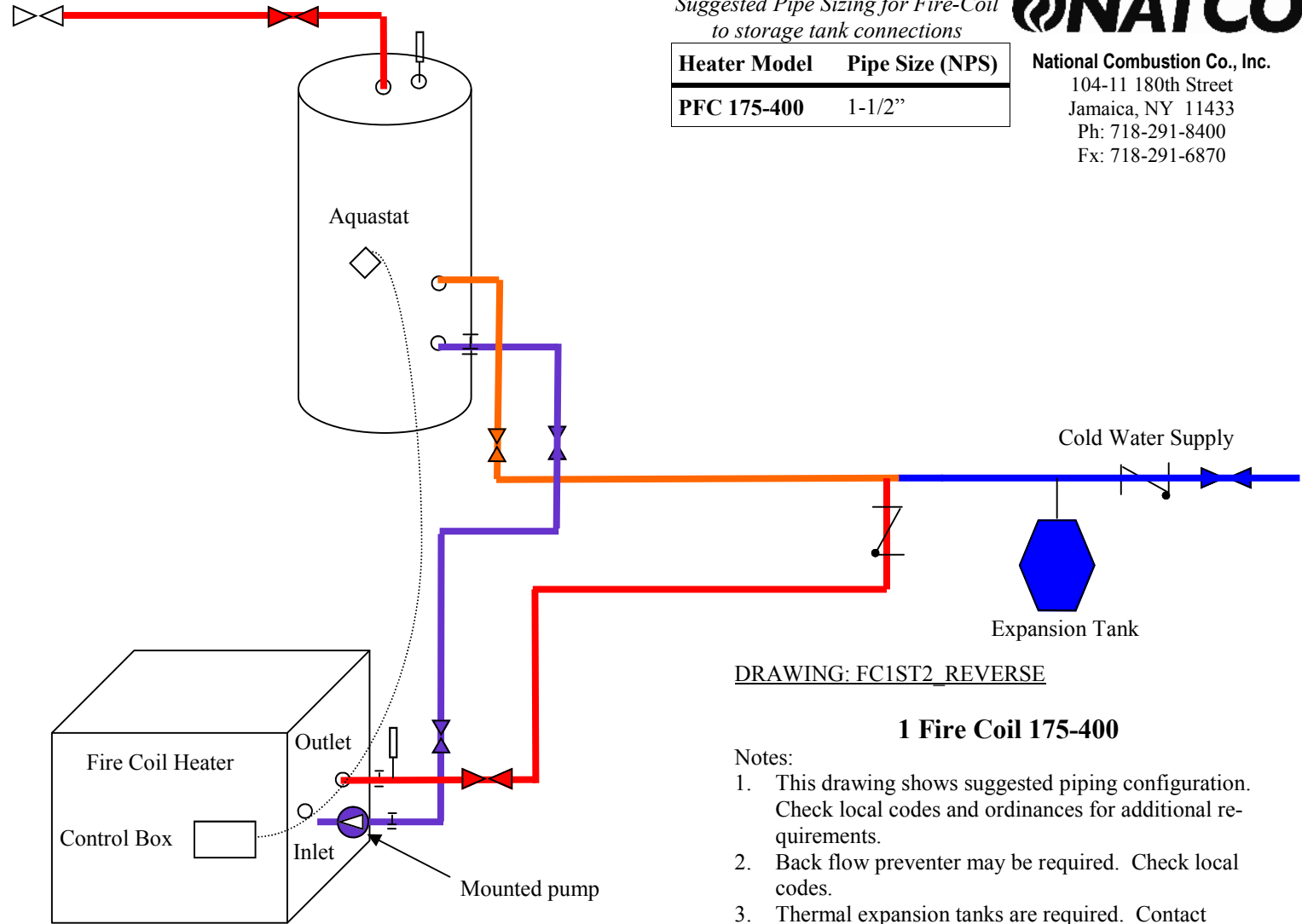

DRAWING: FC1ST2_REVERSE

1 Fire Coil 175-400

Notes:

1. This drawing shows suggested piping configuration. Check local codes and ordinances for additional requirements.
2. Back flow preventer may be required. Check local codes.
3. Thermal expansion tanks are required. Contact NATCO for advice.
4. Additional ball-valves, drain valves, and unions should be used for ease of maintenance (i.e. to isolate and/or drain, heaters, tanks, and pumps).
5. Suggested pipe size must be used throughout, with bushings used to meet connections as necessary. Supply and return pipe diameter must be the same.

Legend



Ball Valve



Circulating Pump

Thermometer



125 PSI Relief Valve



Expansion Tank



Check Valve

Drain Valve