

Installation and Operating Instructions for

Natco Fire Coil

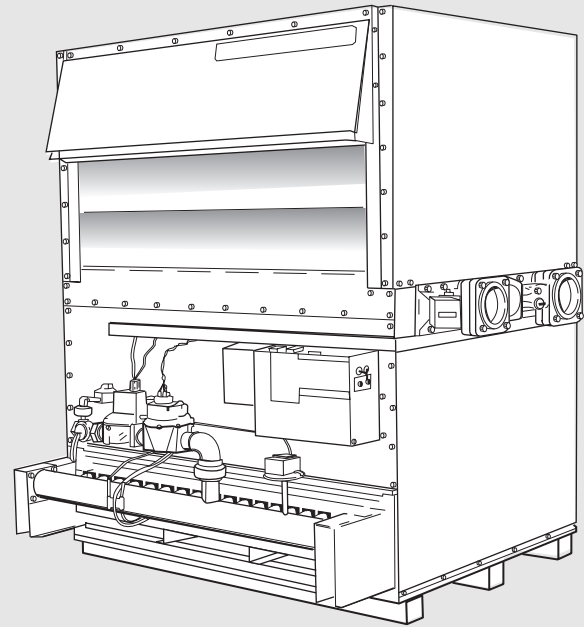
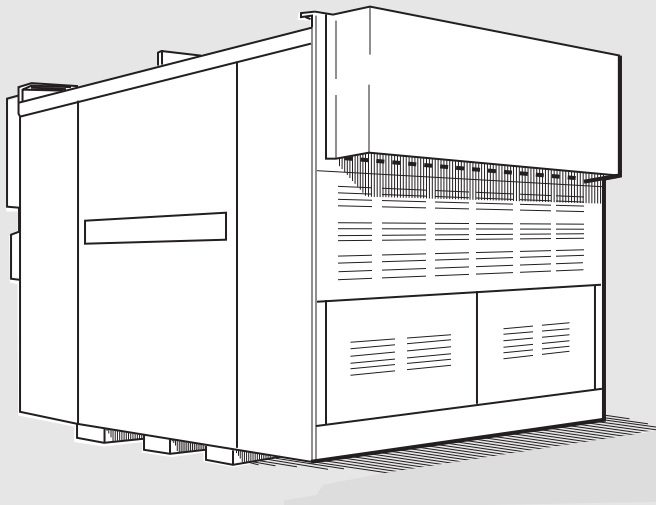

Model VW

Volume Water Heater

Sizes 2000-5000

These instructions are to be stored in the packet provided on the heater

FOR YOUR SAFETY:

Do not store or use gasoline or other flammable vapors and liquids in the vicinity of this or any other appliance.

WARNING:

Improper installation, adjustment, alteration, service or maintenance can cause injury or property damage. Refer to this manual. For assistance or additional information consult a qualified installer, service agency or the gas supplier.

FOR YOUR SAFETY – WHAT TO DO IF YOU SMELL GAS:

- Do not try to light any appliance.
- Do not touch any electrical switch; do not use any phone in your building.
- Immediately call your gas supplier from a neighbor's phone. Follow the gas supplier's instructions.
- If you cannot reach your gas supplier, call the fire department.

Contents

<u>SECTION 1</u>	General Information		<u>TABLES AND FIGURES</u>		
1A.	Introduction	3	TABLE 1	Minimum Heater Clearances	4
1B.	Flow Requirements	4	TABLE 2	Minimum Recommended Air Supply To Heater	5
1C.	Water Chemistry	4	TABLE 3	Gas Line Selection	7
<u>SECTION 2</u>	Installation		TABLE 4	Pump Performance Requirements	9
2A.	Heater Placement	4	FIGURE 1	Heater Configuration - VW	3
2B.	Installation of Indoor Heaters	5	FIGURE 2	Non-combustible Base	4
2B-1	Combustion Air Supply	5	FIGURE 3	Draft Inducer/Power Venter	6
2B-2	Venting	5	FIGURE 4	Incorrect Outdoor Installation	6
2C.	Installation of Outdoor Heater	6	FIGURE 5	T-Fitting Sediment Trap Installation	7
2D.	Gas Supply and Piping	6	FIGURE 6	Gas Piping Diagram	7
2E.	Electrical Wiring	8	FIGURE 7	Tempering Valve Installation	8
2F.	Water Piping of System	8	FIGURE 8	Thermometer Bulb	8
2G.	Water Expansion	8	FIGURE 9	Supply-Flo Two Temperature Hot Water Supply System with Vertical Tank	10
2H.	Pump Installation	9	FIGURE 10	Safety-Flo Two Temperature Hot Water Supply with Horizontal Tank	10
2I.	Tank Installation	9	FIGURE 11	One Temperature Hot Water Supply System with Vertical Tank	11
2J.	Water Pressure	10	FIGURE 12	One Temperature Hot Water Supply System with Horizontal Tank	11
2K.	Piping of Heater to System	10	FIGURE 13	Safety-Flo Two Temperature Hot Water Supply with Vertical Tank (2 Heaters)	11
<u>SECTION 3</u>	Operation		FIGURE 14	Pilot Location	13
3A.	Initial Start-up	12	FIGURE 15	Periodic Flame Observation	13
3B.	To Start Up System	12	FIGURE 16	Removal of Indoor Parts	17
3C.	To Turn Off Heater	13	FIGURE 17	Outdoor Parts Identification	18
3D.	To Shut Down System	13	FIGURE 18	Tile Assemblies	20
<u>SECTION 4</u>	Maintenance	13	FIGURE 19	Parts Identification	22
<u>SECTION 5</u>	Troubleshooting	14			
<u>SECTION 6</u>	Conversion of VW Series from Indoor to Outdoor Models	16			
<u>SECTION 7</u>	Parts Description and Order Numbers	19			

Section 1

General Information

IMPORTANT WARNING: *The Model VW Volume Water Heater must be installed in accordance with the procedures outlined in this manual. Warranty does not apply to heaters not installed or operated in accordance with these procedures. Consult local building and safety codes before proceeding with work. The installation must conform to the requirements of the authority having jurisdiction or, in the absence of such requirements, to the latest edition of the National Fuel Gas Code, ANSI Z223.1, and/or in Canada, CANI B-149 requirement.*

When required by the authority having jurisdiction, the installation must conform to American Society of Mechanical Engineers safety code for controls and safety devices for automatically fired heaters No. CSD-1, and in Canada CGA 3.3. Any modification to the water heater, its gas controls, gas orifices, wiring or draft diverter may void the Natco warranty. If field conditions require such modifications, consult factory.

1A. Introduction

This manual provides information for the installation and operation of Natco Volume Water Heaters. It is strongly recommended that all application and installation procedures be reviewed completely before proceeding with the installation. Consult the factory, or local factory representative, with any problems or questions regarding this equipment. Experience has shown that most operating problems are caused by improper installation.

Model VW heaters are available from the factory in two configurations: An indoor version and an outdoor version. In addition, the heaters are field convertible. See Section 6 of this manual.

Some accessory items are shipped in separate packages. Verify receipt of all packages listed on the packing slip. Inspect everything for damage immediately upon delivery, and advise the carrier of any shortages or damage. Any such claims should be filed with the carrier. The carrier, not the shipper, is responsible for shortages and damage to the shipment whether visible or concealed.

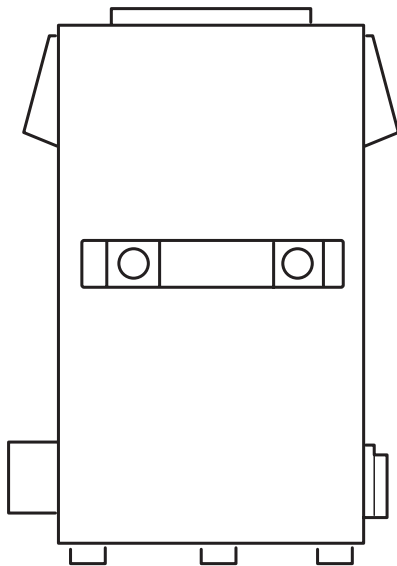

Indoor

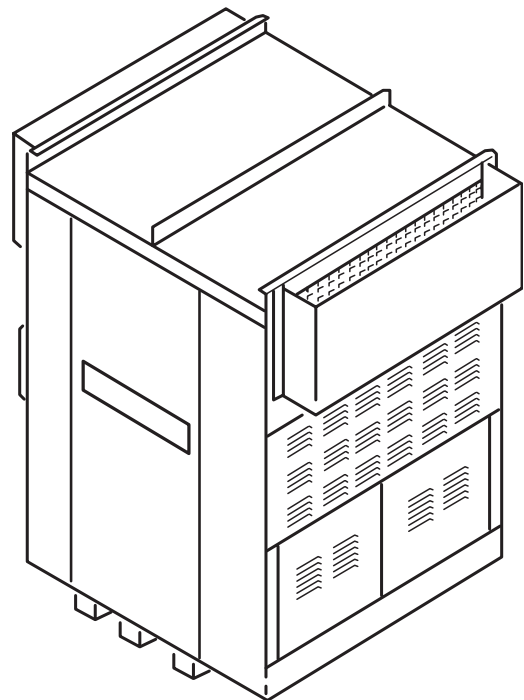

Outdoor

When heater is ordered with stage or modulated control and sales order states it is to be used on a variable flow system, the temperature controller is factory installed in the water outlet.

Figure 1 – Heater Configuration - Model VW

1B. Flow Requirements

All low volume hot water heaters must have continuous flow through the heat exchanger when firing for proper operation. The system pump must be capable of developing sufficient pressure to overcome the resistance of the heater plus the entire circulating system at the designed flow rate.

1C. Water Chemistry

Natco equipment is designed for use in a wide variety of water conditions. The water velocity maintained in the heat exchanger tubes is kept high enough to prevent scaling from hard water, and at the same time, low enough to avoid corrosion from soft water. Most of the urban areas in the country have water that is compatible with this equipment. In some areas a water supply will contain a heavy quantity of scaling chemicals, or the water may be extremely soft and corrosive. In rare situations, the water will contain both scaling chemicals and corrosive chemicals such as calcium, or sodium chloride. These conditions may be the result of a nearby well or pumping station, and the particular condition may not be characteristic of the entire city water system.

If an installer observes damage from these conditions to any water handling equipment in the area, a factory representative should be contacted immediately for assistance in minimizing maintenance costs. If erosion is present, the pump impeller can be replaced to reduce water velocity. If scaling conditions are bad, tube cleaning maintenance schedules can be established to prevent tube burn-out and cracking. Neglecting the problem could mean serious damage to the heater and water system.

Scaling can be recognized as a layer deposited on the inner walls of the tubes which reduces the inner diameter of the tube. Scale can be any color or texture; smooth or rough, granular or amorphous. Erosion is generally evidenced by pitting, cavitation, ridges and "islands" on the inner walls of the tubes. Where this condition results from extremely soft water sources, or as a result of a water softening program, the internal copper surfaces will be extremely shiny. Other chemicals, such as chlorine or chlorides in the water, will result in dark surfaces of erosion.

In areas where the water supply is extremely corrosive, it is advisable to order the heater with cupronickel tubes in the exchanger.

Damage from scaling, corrosion, or erosion is not covered by the warranty.

Section 2 Installation

2A. Heater Placement

The heater must be placed to provide clearances on all sides for maintenance and inspection. There must also be minimum distances maintained from combustible surfaces.

All heaters must be installed on a non-combustible flooring. Under no circumstances can heaters be installed on carpeting.

The National Fuel Code allows a heater to be placed on other than a non-combustible surface when such an installation complies with the local codes. This code specifies the surface under the heater be

Table 1 – Minimum Heater Clearances From Combustible Surfaces

Clearance From	Indoor (Inches)	Outdoor (Inches)
Top	24	—
Water Conn. Side	24	24
Opposite Side	24	24
Front	48	48
Rear	24	24
Vent	6	—

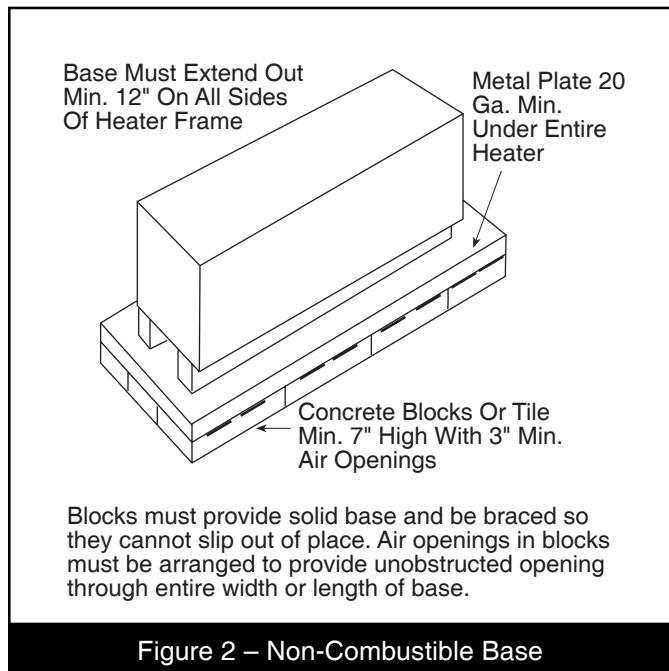

Figure 2 – Non-Combustible Base

protected with hollow masonry no less than 4" thick, covered with sheet metal at least 20 gauge in thickness. Such masonry must be laid with ends unsealed, and joints matched in such a way as to provide a free circulation of air from side to side through the masonry. See **Figure 2**.

2B. Indoor Installation

2B1. Combustion Air Supply

1. The heater location must provide sufficient air supply for proper combustion, and ventilation of the surrounding area as outlined in the latest edition of ANSI standard Z223.1 and in Canada, CAN1-B149 requirement, and any local codes that may be applicable. Inadequate combustion air supply may result in incomplete combustion and consequent sooting of the heat exchanger and unsafe operation of the heater.
2. In general (in the U.S.) these requirements specify that heater rooms, which represent confined spaces, should be provided with two permanent air supply openings communicating directly through the wall to outside air; one within 12 inches of the ceiling, the other within 12 inches of the floor (Consult the factory regarding rooms which do not communicate directly with the outdoors). Each opening should have a minimum free area of one square inch per 4,000 BTUH input of the total input rating of all appliances in the enclosed area. See **Table 2** for recommended air supply for each model. An improperly ventilated equipment room can get excessively hot and cause accelerated deterioration of controls and electrical components.

Note: In Canada (Table 2 does not apply) consult local building and safety codes or, in the absence of such requirements, follow CGA requirement, and/or CAN1-B149 standard.

3. Exhaust Fans or Vents: Any equipment which exhausts air from the heater room can deplete the combustion air supply or reverse the natural draft action of the venting system. This could cause flue products to accumulate in the heater room. Additional air must be supplied to compensate for such exhaust. The information in **Table 2** is not applicable in installations where exhaust fans or blowers of any type are used. Such installations must be designed by qualified engineers.
4. If a blower or fan is used to supply air to the heater room, the installer should make sure it does not create drafts which could cause nuisance shutdowns of the pilot. If a blower is necessary to

Table 2– Minimum Recommended Air Supply To Heater Room

Indoor Size	Each Opening* (Square Inches)
2000	500
2450	613
3050	763
3500	875
4050	1013
4500	1125
5000	1250

Net Free Area in Square Inches*

*Area indicated is for one of two openings; one at floor level and one at the ceiling, so the total net free area would be double the figures indicated. For all other conditions, refer to latest edition of ANSI Bulletin Z223.1.

Note: Check with louver manufacturers for Net Free Area of louvers. Correct for screen resistance to the Net Free Area if a screen is installed. Check all local codes applicable to combustion air.

provide adequate combustion air to the heater, a suitable switch or equivalent must be wired into the heater control circuit to prevent the heater from firing unless the blower is operating.

5. The heater must be completely isolated and protected from any source of corrosive chemical fumes such as emitted by trichlorethylene, perchlorethylene, chlorine, etc.

2B2. Venting

1. Natco heaters have built-in draft diverters for natural draft operation and must not be connected into any portion of a mechanical draft system under positive pressure. The flue outlet must be connected to a clear, unobstructed vent of adequate capacity terminating above the highest point of the building with an approved vent cap. The venting system should be installed according to the latest edition of ANSI Z223.1 and any local codes having jurisdiction, and/or in Canada follow CAN1-B149 standard.

IMPORTANT NOTE: Do not use sheet metal screws at the snap lock joints of Type B gas vents.

2. Do not weld or fasten the vent pipe to the heater draft hood. The weight of the stack must not rest on the heater. The draft hood and heater top must be easily removable for normal heater service and inspection.
3. Avoid long horizontal runs of the vent pipe, and too

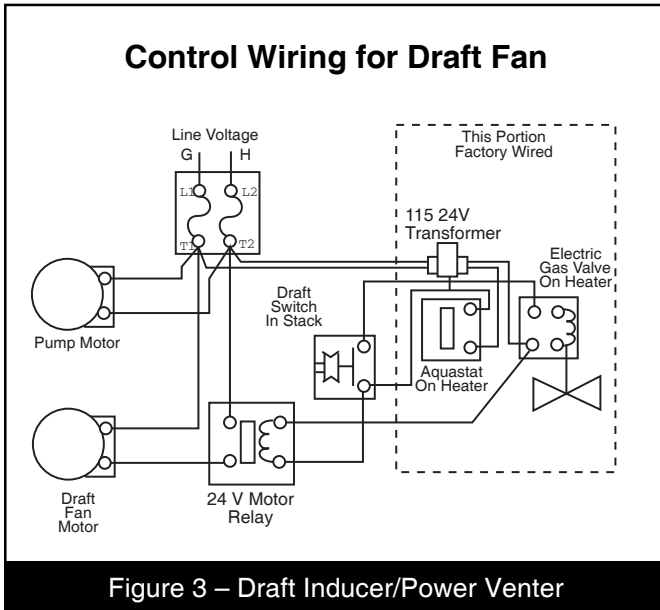

many 90° elbows, reductions and restrictions. Horizontal runs should have at least a 1/4" rise per foot in the direction of flow. A vent connector shall be supported for the design and weight of the material employed to maintain clearances and prevent physical damage and separation of joints.

4. Avoid terminating heater vents near air conditioning or air supply fans. The fans can pick up exhaust flue products from the heater and return them inside the building, creating a possible health hazard. A minimum of 4 feet horizontal distance must be maintained from electric meters, gas meters, and relief equipment.
5. Always use double-wall or insulated vent pipe (Type B or equivalent). In cold weather, uninsulated outside vents can chill the rising flue products, blocking the natural draft action of the venting system. This can create a health hazard by spilling flue products into the heater room.
6. Avoid oversize vent piping or extremely long runs of the pipe which may cause excessive cooling and condensation. Rule of Thumb: The total length of the vent, including the connector and any offset, should not exceed 15 feet for every inch of vent diameter. Longer total lengths shown in venting tables are based on maximum capacity, not condensation factors.
7. When the installation of a draft fan is necessary in the venting system to which a Natco heater is to be connected, the installation should be engineered by competent personnel following good engineering practices. The draft fan supplier should be consulted for correct size. The installation should be in accordance with the latest edition of ANSI

Z223.1 and any local codes having jurisdiction. In Canada follow CAN1-B149 standard. When a draft fan is installed, a suitable draft switch must be used and wired into the heater control circuit at terminal designated "Field Interlock," to prevent firing of the heater unless a positive draft has been established (see **Figure 3**).

2C. Installation of Outdoor Heater

CAUTION: *Outdoor installations are not recommended in areas where the danger of snow blockage exists.*

1. Locate the heater to provide the minimum clearances as listed in Section 2A, "Placement of Heater."
2. Do not locate the heater in an enclosure or wall recess. Avoid location where wind deflection off structures might cause down draft. When such wind conditions are possible, locate the heater at least three(3) feet from the structures.
3. Never install the heater under any kind of roof overhang. Do not locate the heater below or adjacent to any doors, windows, louvers, grills, etc. which communicate in any way with an inhabited area of a building. Even though such communication might be through another structure such as a garage or utility room (see **Figure 4**).

2D. Gas Supply and Piping

Review the following instructions before proceeding with the installation.

1. Verify that the heater is fitted for the proper type of gas by checking the rating plate. Natco heaters are normally equipped to operate below a 2000 foot altitude. Heaters equipped to operate at higher altitudes have appropriate stickers or tags attached.

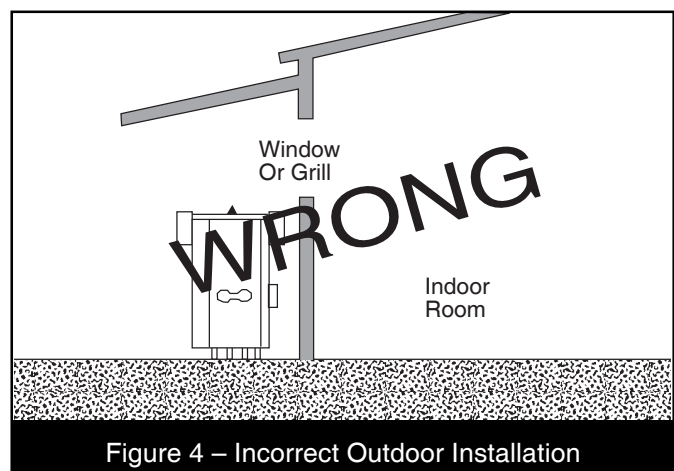

- Use the figures in **Table 3** to provide adequate gas piping (check local code for BTU capacity required). See **Table 4**.
- A trap (drip leg) must be provided ahead of the gas controls (see **Figure 5**). Where required by code, provide a second manual gas shutoff valve. Do not remove manual valve furnished with the heater.
- The heater and its individual shutoff valve must be disconnected from the gas supply piping system during any pressure testing of that system at test pressures in excess of 1/2 psig. The heater must be isolated from the gas supply piping system by closing its individual manual gas shutoff valve during any pressure testing of the gas supply piping system at test pressures equal to or less than 1/2 psig.

- Provide gas supply pressure to the heater as follows:

	Natural Gas	LPG
Min. (inches water column)	7	11
Max. (inches water column)	9	14

Note: The heater and all other gas appliances sharing the heater gas supply line must be firing at maximum capacity to properly measure the inlet supply pressure. Low gas pressure could be an indication of an undersize gas meter and/or obstructed gas supply line.

- The correct burner manifold gas pressure is stamped on the rating plate. The regulator is pre-set at the factory, and normally requires no further adjustment.
- The gas manifold and control assembly was tested and conform to the safe lighting and other performance criteria specified in the latest editions of ANSI Z21.13 and CGA 3.3 Low Pressure Heater Standard.
- Before operating the heater, the complete gas supply system and all connections must be tested for leaks using a soap solution. Do not use raw flame.

Table 3 – Gas Line Selection Chart For Natural and Propane Gas

Distance from Gas Meter or Last Stage Regulator							
Indoor Size	Outdoor Size	0-100'		100-200'		200-300'	
		Nat.	LP	Nat.	LP	Nat.	LP
2000	—	2-1/2	2	3	2-1/2	3	3
2450	2200	3	2-1/2	3	2-1/2	3-1/2	3
3050	2800	3	2-1/2	3-1/2	3	3-1/2	3
3500	3200	3	2-1/2	3-1/2	3	4	3-1/2
4050	3600	3-1/2	3	4	3-1/2	4	3-1/2
4500	4000	3-1/2	3	4	3-1/2	5	4
5000	4500	4	3-1/2	4	3-1/2	5	4

NOTES:
 These figures are based on 1/2" water column pressure drop.
 Check supply pressure and local code requirements before proceeding with work.
 Pipe fittings must be considered when determining gas pipe sizing.

CAUTION: Since some leak test solutions, including soap and water, may cause corrosion or stress cracking, the piping must be rinsed with water after testing, unless it has been determined that the leak test solution is noncorrosive.

Arrangement of gas train components for on-off, 2-stage and 4-stage firing are shown schematically in the Gas Piping Diagram. See **Figure 6**.

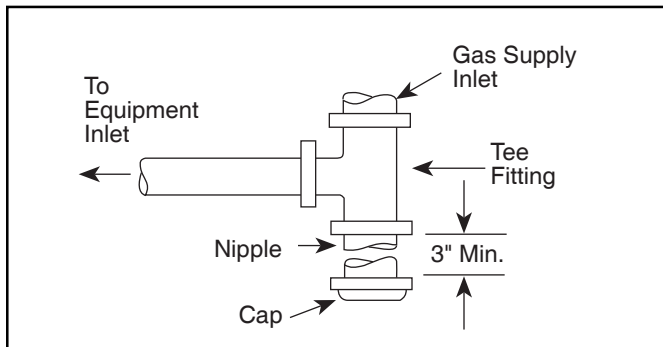

Figure 5 – T-Fitting Sediment Trap Installation

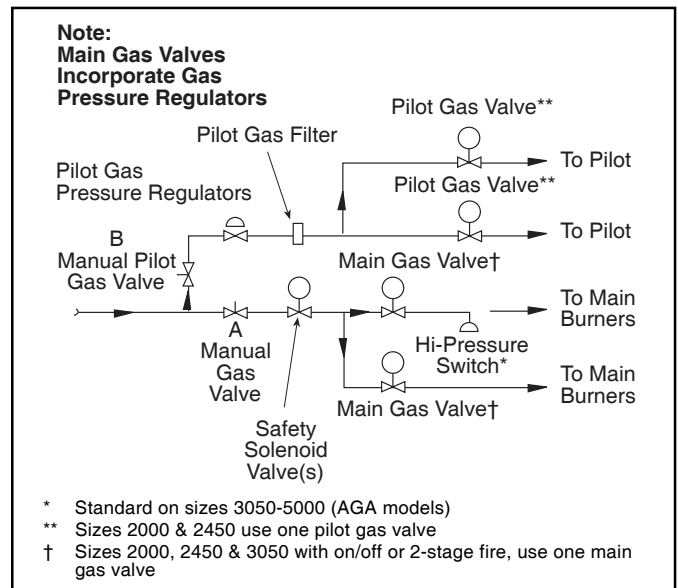

Figure 6 – Gas Piping Diagram

2E. Electrical Wiring

Electrical diagrams are included with the packet provided with each unit.

WARNING: *The heater must be electrically grounded in accordance with the most recent edition of the National Electrical Code and ANSI/NFPA 70, and in Canada, follow Canadian Electrical Code CSA C22.1. Do not rely on the gas or water piping to ground the metal parts of the heater. Many times, plastic pipe or dielectric unions isolate the heater electrically. Service and maintenance personnel who work on or around the heater may be standing on wet floors and could be electrocuted by a poorly grounded heater.*

1. Check heater wiring and pump for correct voltage, frequency and phase. If the pump circuit is other than 115V, check to see that the heater is provided with an appropriate transformer.
2. Wire the heater and pump exactly as shown in the wiring diagram supplied with the heater.
3. The pump and heater must be electrically interlocked so the heater cannot come on unless the pump is running.
4. All field installed electrical safety devices and all field installed devices (draft switches, relays, timers, outdoor temperature reset devices, etc.) can be connected to the heater wiring at points shown in the wiring diagram designated "Field Interlock."

2F. Water Piping of System

1. Be sure to provide valves at the inlet and outlet to the heater so it can be readily isolated for service. A butterfly or similar type of valve is recommended.
2. The pressure relief valve must be installed in the tapped opening provided in the heater header, or on the "T" connection on the heater outlet side, with its outlet piped but not fastened to a drain or floor sink. Special attention must be given to relief valve settings in installations where the heater is located

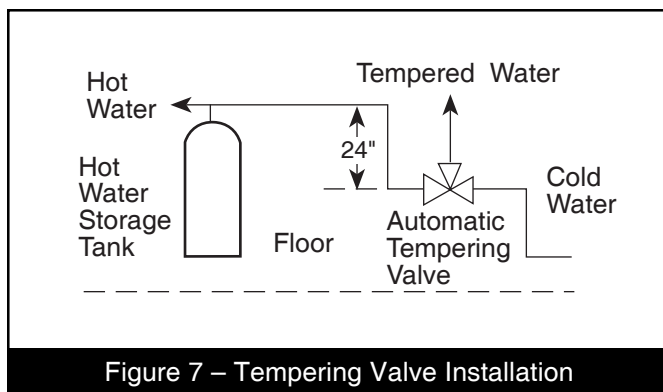

Figure 7 – Tempering Valve Installation

on the ground floor of a tall building. In both instances, the static pressure of the system is elevated, and could cause the relief valve to leak. Where no special setting of the relief valve is ordered, the factory will furnish a 125 psi setting. Never reduce the relief valve opening. If necessary, install the relief valve in a Tee immediately past the heater outlet.

3. The weight of all water and gas piping should be supported by suitable hangers or floor stands.
4. Check piping diagrams with local applicable plumbing, heating and building safety codes.
5. All two-temperature systems using temperature valves must have forced recirculation in the low temperature building loop.
6. A check valve installed at the hot water inlet to the tempering valve will prevent cold water from being drawn in reverse through the tempering valve into the hot water.
7. When installing a tempering valve, locate it at the bottom of the antithermosyphon loop at least 24" high to prevent excessive hot water from entering the mixed water supply (**Figure 7**). Bring the cold water supply up from the floor to the valve.
8. Keep thermometer bulbs in moving water. Use of a bushing will cause temperature readings to be off 10° or more (**Figure 8**).
9. Insulate all pipes containing hot water, especially in unheated areas. Sizing charts assume this condition exists. Excessive heat loss of exposed piping adds to gas consumption and could result in insufficient hot water during peak demand periods. If pipes are uninsulated, a larger heater must be used.

2G. Water Expansion

When cold water is heated, it expands. If no water is being used during the heat-up period, the expanded water will normally back up into the city mains.

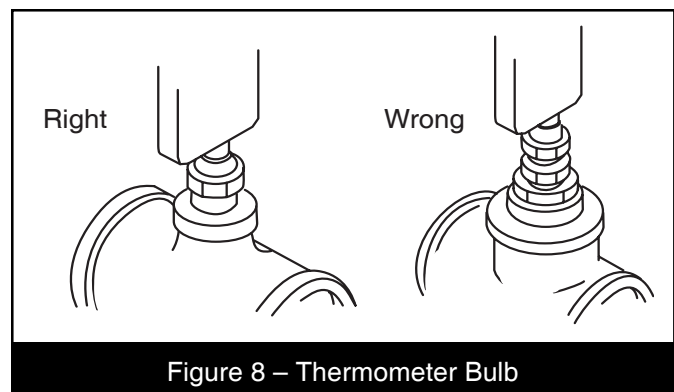

Figure 8 – Thermometer Bulb

A water pressure reducing valve installed in the incoming cold water line may act as a check valve, and prevent the expanded water from backing up. This will result in a pressure rise in the heater, which will be relieved by the pressure relief valve. If the relief valve pops frequently, a mineral deposit may build up on the valve seat, causing a leak.

The following suggestions may solve the problem:

1. Replace the installed water pressure reducing valve with a suitable valve having a back-flow port. These valves allow water to flow backwards when the pressure in the system exceeds the pressure in the mains.
2. Install a check valve around the pressure reducing valve which will permit reverse flow. This will permit the expanded water to back flow into the mains.
3. Install an auxiliary small relief valve set at 25 psi less than the main relief valve. The valve must be piped to a drain, and may require occasional cleaning. It will bleed off the expanded water, and protect the main pressure relief valve from becoming fouled.
4. Install a properly sized expansion tank.

2H. Pump Installation

A suitable pump must be field installed on Model PVW heaters to provide circulation between the heater and the storage tank. The pump must be sized to avoid an excessive temperature rise and to provide correct flow for the existing water hardness conditions. The specification in the following table include allowances for 30 feet of piping and normal fittings between the heater and the storage tank.

IMPORTANT: Check the oil level in the pump before starting. Oil the pump every 3 months. Fill the bearing assembly to lower level of the overflow vent. Add 5 or 6 drops of oil to front and rear of motor. Use 20W non-detergent oil. Pumps located in very hot or dusty locations should be oiled once a month. Self-lubricating pumps do not require oiling.

1. Install the heater in a cool location to avoid damage to the pump, accidental tripping of a thermal switch if one is installed, and scaling in the heater.
2. The pump must be accessible for lubrication, inspection and service.
3. If the pump is designed for floor mounting, install it securely on concrete block or pad at least 6 inches above floor level. This will prevent flooding of the motor when the floor is washed. Be sure that floor mounted pumps are not suspended from piping, and that piping is plumbed to avoid putting strain on the pump casing.

2I. Tank Installation

1. Be sure the floor is structurally capable of supporting the tank when it is filled with water, and is waterproof.
2. The tank should be placed so that manholes, inspection covers, nameplates and drain valves are accessible.
3. Be sure the tank is suitable for the water in the system. Some water is corrosive and requires a protected tank with a special lining.
4. If the tank is glass lined, it should be equipped with a suitable magnesium anode. It is a good practice to replace the anode when it is approximately 50% used. The factory warranty on a glass-lined tank will be void if a satisfactory anode is not in place at

Table 4 – Pump Performance Requirements

Size	Water Cat.	Flow Rate (GPM)	Head Loss** (ft.)	Temp. Rise Across Heater (F)	
				Indoor	Outdoor
2000 I	Soft	100	4.2	33	–
	Normal	150	9.0	22	–
	Hard	200	15.0	16	–
2450 I 2200 E	Soft	100	4.5	40	35
	Normal	150	9.7	27	24
	Hard	200	16.0	20	18
3050 I 2800 E	Soft*	200	6.1	25	22
	Normal	150	11.0	34	29
	Hard	200	18.0	25	22
3500 I 3200 E	Soft*	200	6.3	29	25
	Normal	150	11.0	38	34
	Hard	200	19.0	29	25
4050 I 3600 E	Soft*	200	6.7	33	29
	Normal	150	12.0	44	39
	Hard	200	20.0	33	29
4500 I 4000 E	Soft*	200	6.9	37	32
	Normal*	180	17.0	41	36
	Hard	200	21.0	37	32
5000 I 4500 E	Soft*	200	7.2	41	36
	Normal*	180	18.0	46	40
	Hard	200	22.0	41	36

I = Indoor E = Outdoor
* These heaters are single pass.

** Pressure drop includes loss through 30 feet of pipe and normal fittings when heater is installed with storage tank. Pipe and fittings are assumed to be 4".

the time of a failure or if it is consumed by cathodic action.

5. Make sure the tank connections in the heater-tank circulating loop are the proper size as listed in **Table 4**. If tappings are smaller than the recommended pipe size, a larger pump may be required. Consult the factory if in doubt.
6. Install a pipe in the tank drain fitting that goes to a floor sink, and install a drain valve. If a floor sink is not available, install a hose bib.
7. Hot water tanks in an existing installation are likely to have a deposit of silt on the bottom. Therefore, it is important to extend the pump suction pipe in the tank to a position near the top. Pipe the return from the heater to the bottom of the tank.

2K. Piping of Heater to System

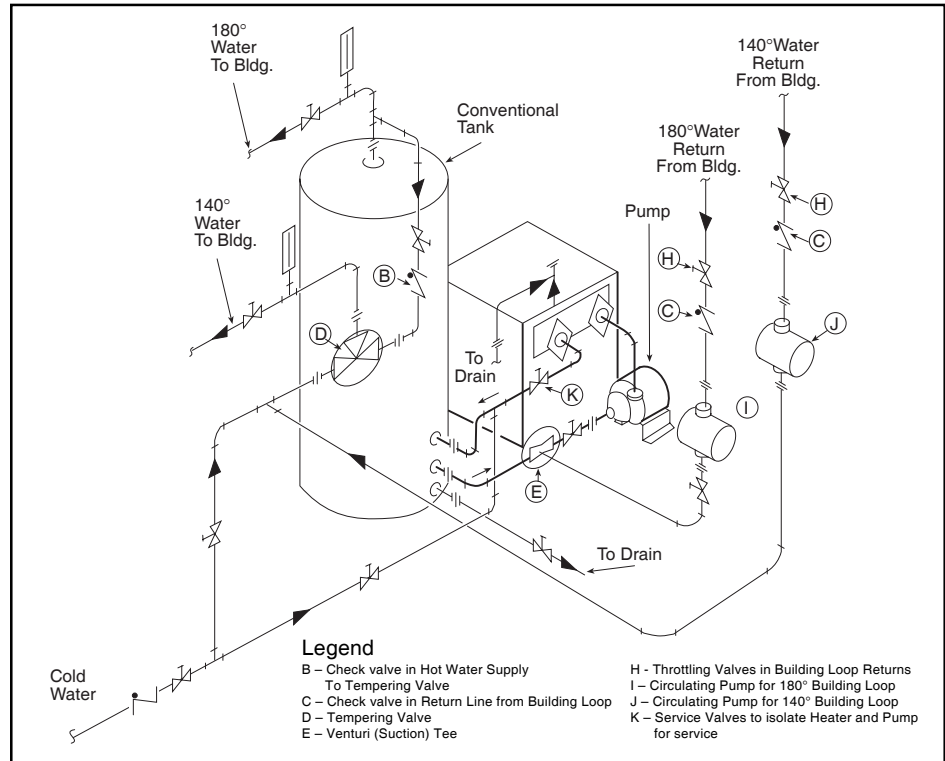

Figure 9 – Supply-Flo Two Temperature Hot Water Supply System with Vertical Tank

2J. Water Pressure

It is very important that at least 30 psi water pressure in the system is maintained. If the pressure drops below this level, damage to the heater through lack of circulation can occur. If, for any reason, the water supply is turned off temporarily, to service a piece of equipment for instance, the manual gas valve on the heater should be closed until the water pressure has been restored and the lines bled of accumulated air. If the heater fails to fire when it is turned back on, it could be airlocked. To eliminate the airlock, open the pressure relief valve and allow the air to escape. When full circulation is restored, any residual air in the lines will be released through the faucets.

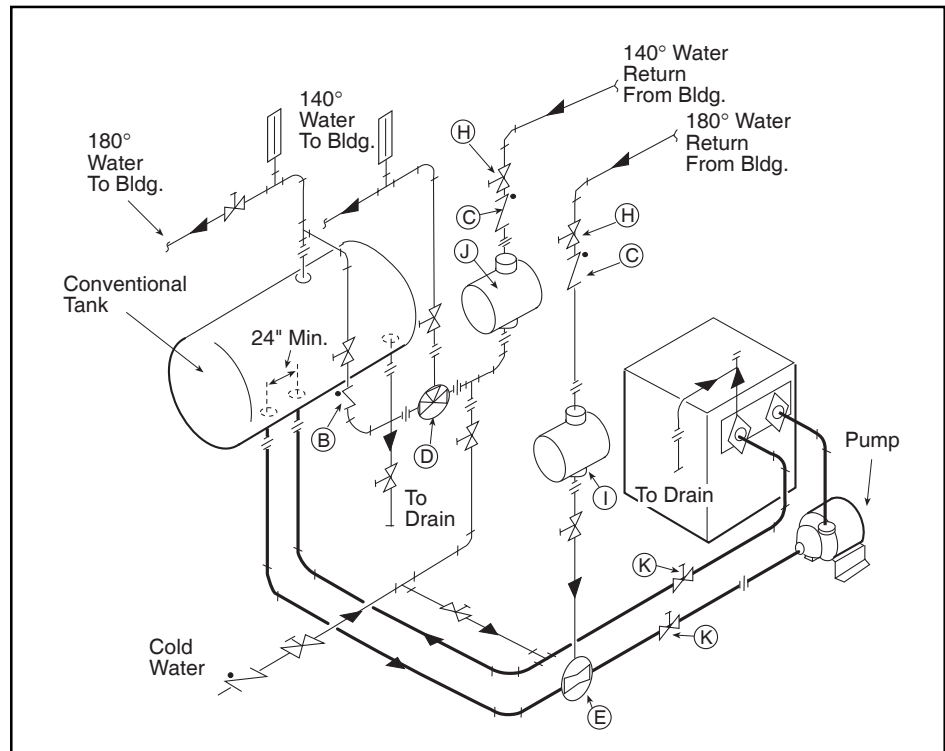

Figure 10 – Safety-Flo Two Temperature Hot Water Supply System with Horizontal Tank

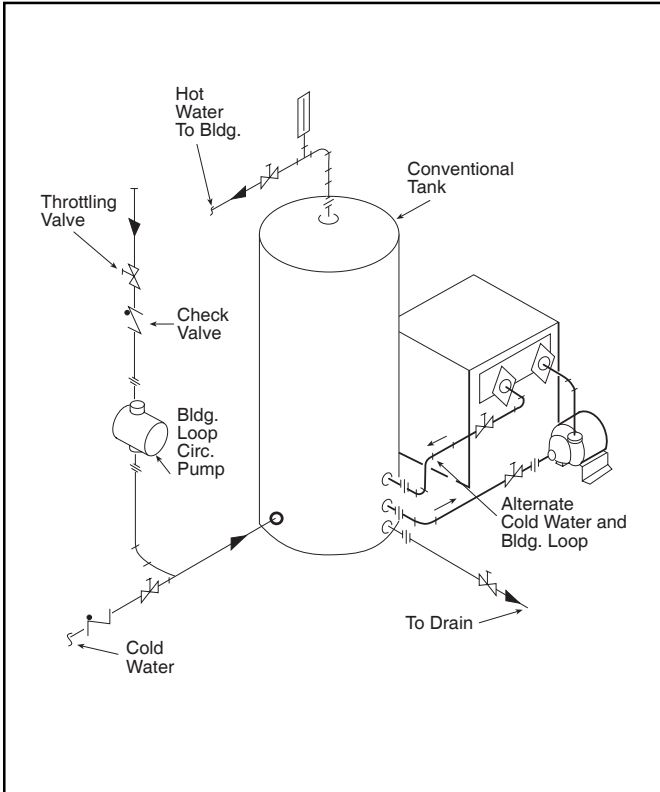
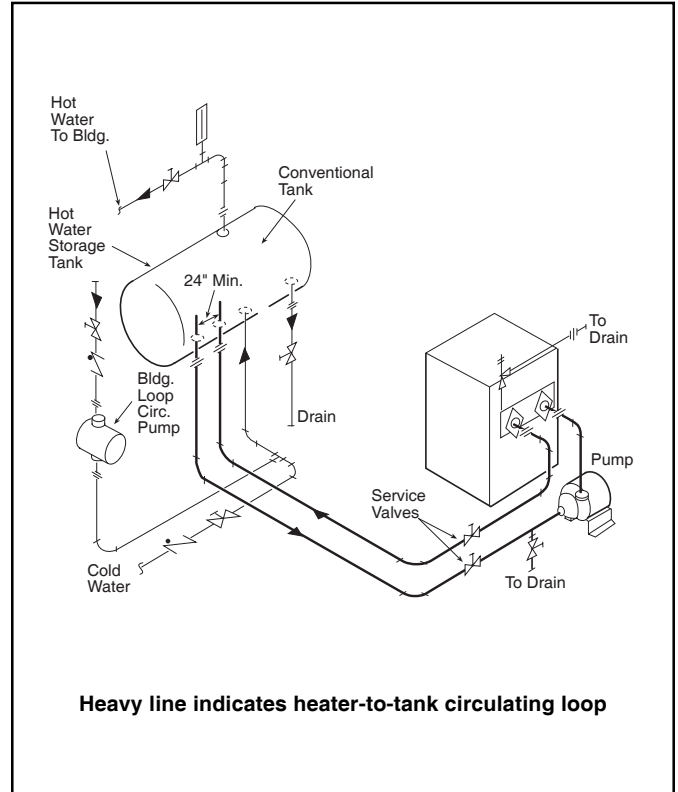
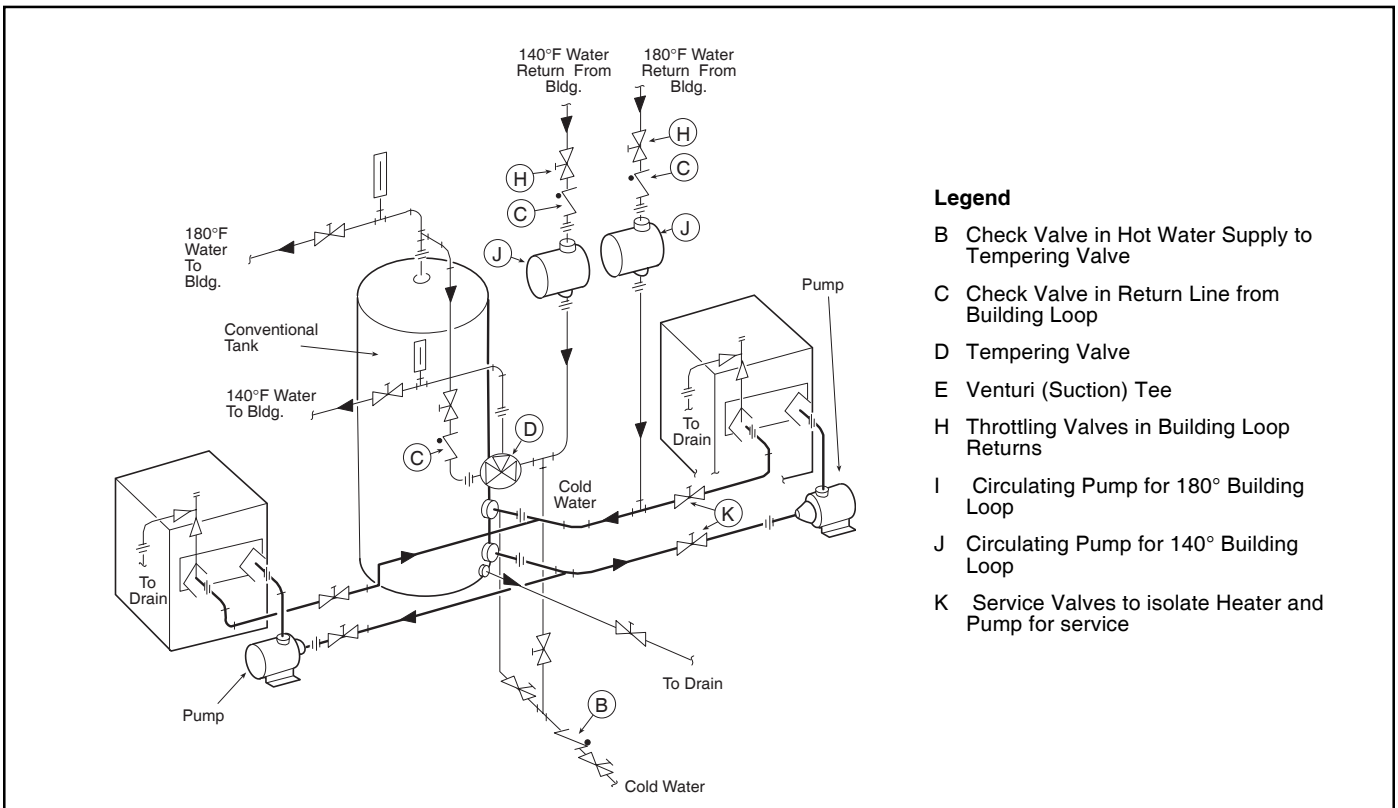

Figure 11 – One Temperature Hot Water Supply System with Vertical Tank



Heavy line indicates heater-to-tank circulating loop

Figure 12 – One Temperature Hot Water Supply System with Horizontal Tank



Legend

- B Check Valve in Hot Water Supply to Tempering Valve
- C Check Valve in Return Line from Building Loop
- D Tempering Valve
- E Venturi (Suction) Tee
- H Throttling Valves in Building Loop Returns
- I Circulating Pump for 180° Building Loop
- J Circulating Pump for 140° Building Loop
- K Service Valves to isolate Heater and Pump for service

Figure 13 – Safety-Flo Two Temperature Hot Water Supply System with Vertical Tank (Two Heaters)

Section 3 Operation

3A. Initial Start Up

Lighting: *Safe lighting and other performance criteria were met with the gas manifold and control assembly provided on the heater when it underwent tests specified in the ANSI Z21.13 standard.*

Before placing the heater in operation, the automatic safety shutoff devices must be checked. Once the heater is connected to the gas piping and after all of the requirements in Section 2 have been met, follow this procedure:

1. Before beginning the tests, make sure the main manual gas valve, and any other heater firing valves, are in the OFF position.
2. Make sure the power switch on the heater is in the "ON" position. After placing the manual pilot valves in the open position, and resetting all safety devices (high limit, pressure switch, low-water-cutoff, etc.), pilots can be lit following the procedure located on the heater rating plate.
3. Once the pilots are lit and have been established for five minutes, the flame failure response time should be checked as follows:

System 16: (Electronically supervised standing pilot system standard on propane gas) Extinguish the pilot flame by placing the manual pilot valve in the closed position, and, at the same time, begin recording the time it takes for the output signal from the electronic ignition control to be interrupted. Refer to the electrical drawing supplied with the heater for wiring details. The signal interruption can be detected either with a test light or a voltmeter. Because the ignition controls are in series, the control just upstream of the gas valves should be tested first. Under no circumstances should the response time exceed 5 seconds.

System 18: (Intermittent ignition supplied only for natural gas) With this system, pilots are automatically lit when the thermostat calls for heat. The pilots are permitted a trial period for ignition, then the system is locked out if it fails to light. To retry ignition, power to the heater must be momentarily interrupted. After the pilot is initially lit, the trial for ignition time should be checked by turning off pilot gas, and, at the same time, monitoring the time it takes for the audible sparking at the pilot burner to stop. Under no circumstances should the trial for ignition exceed 15 seconds. Because the electronic ignition controls are in series, the control just upstream of the gas valves should be tested first (refer

to the electrical drawing supplied with the heater).

Once the trial for ignition period has been checked, the controls should be reset and the flame failure response time checked by following the procedure given for System 16.

4. With the pilots lit, initial activation of the main burners can be achieved by slowly opening the main manual valve. The result should be a smooth lighting of the main burners.

Hi-Limit Checkout

After running the heater for a long enough period to bring the water temperature within the range of the hi-limit, slowly back off the high limit setting until the heater shuts off. The main burners should re-ignite when the hi-limit is turned back up to its original setting.

The high limit should now be reset and the heater run until it shuts off automatically on high limit.

3B. To Start Up System

1. Start up heater.
Be certain system pump is running.
2. Lighting instructions are provided on the heater rating plate and in the User's Manual and are as follows:
 - a. Turn off main electrical switch.
 - b. Turn off all manual gas valves and wait five minutes.
 - c. Set aquastat or thermostat to lowest setting.
 - d. Slowly turn manual gas valve to ON.
 - e. Reset all safety valves (pressure switch and manual reset high limit).
 - f. Open manual pilot valve. Turn on main electrical switch.
 - g. Set temperature controller to desired temperature. Pilot will light automatically to ignite main burners whenever the thermostat calls for heat.
 - h. The low firing rate setting must be equal to or greater than the specified minimum input rating as shown on the appliance rating plate. For example, size 2450 has a specified minimum input of 735,000 BTU/hr. The unit's input rate must not be below this value (refer to rating plate. Natco's boilers/heaters use gas valves which are factory set to provide an input on low fire that meet or exceed the specified minimum.

3. To set temperature controls:

Heaters on constant flow will have the temperature controller bulb located in the heater inlet and the high limit sensing bulb in the heater outlet.

Heaters on variable flow will have both the temperature control sensing bulb and the high limit sensing bulb located in the heater outlet.

When heater is installed on a constant water flow system, set temperature controller at the designed system supply temperature less the temperature drop in the system. Set the high limit switch 30°F above the supply temperature to the system.

When heater is equipped with staged or modulated fire and installed on a variable flow system, set temperature controller at the designated system temperature. Set the high limit switch 30°F above the supply temperature to the system.

3C. To Turn Off Heater

1. Turn off main electrical switch.
2. Close all manual gas valves.

3D. To Shut Down System

To shut down heater, turn off all manual gas valves and electrical disconnect switch. Whenever danger of freezing exists, shut off water supply and remove drain plug in bottom of front header cover and drain every part of system subject to freezing temperatures.

Section 4 Maintenance

1. If a strainer is employed in a pressure reducing valve or in the piping, clean it every six (6) months.
2. At start-up and every six (6) months thereafter, the pilot and main burner flame should be observed for proper performance (see **Figures 15** and **16**; see attached lighting and shutdown instructions for proper pilot flame pattern). If flame has the appearance of “sooting” tips, check for debris near orifices. Call service technician.
3. Inspect the venting system for obstruction, leakage, and corrosion at least once a year.
4. Keep heater area clear and free from combustible material, gasoline and other flammable liquids and vapors. Heater surfaces are hot and could ignite combustible material.
5. Be certain all combustion air and ventilation openings are unobstructed.

6. Check for fouling on the external surfaces of the heat exchanger every six months.

Note: After installation and first start-up, check the heat exchanger for fouling after the following periods of operation: 24 hours, 7 days, 30 days, 90 days, and once every six months thereafter.

Fouling on the external surfaces of the heat exchanger is caused by incomplete combustion, and is a sign of combustion air and/or venting problems. As soon as any fouling is observed, the cause of the fouling should be corrected (see Section 5 Troubleshooting). The heat exchanger can be checked with a flashlight by locating a mirror under the burners. An alternate method is to remove the venting and top panel as necessary to inspect from above. Also, check the vent system for defects at the same time.

- a. If cleaning is required, shut off all electrical and gas supply to the heater.

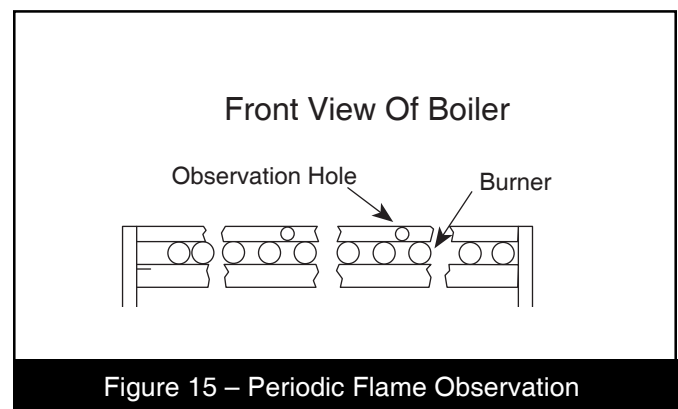
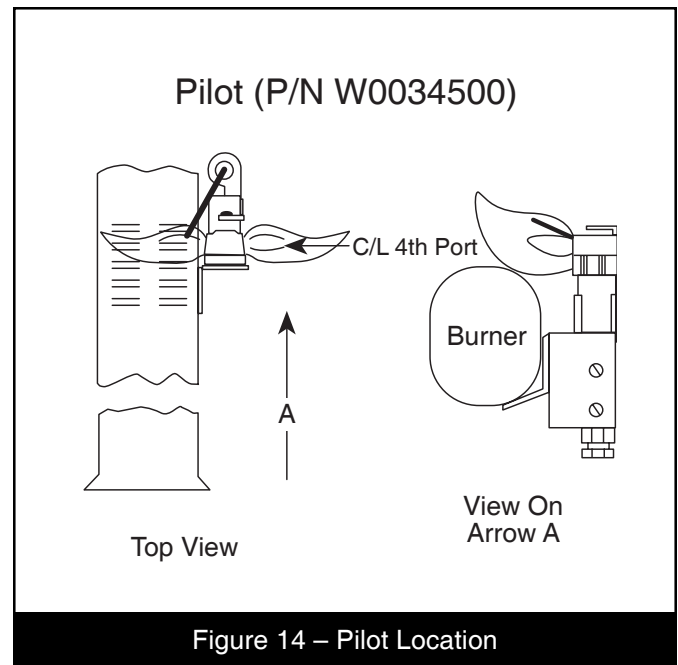

- b. To expose the heat exchanger:

Remove top panel covers located at the base of the front and rear flue collector panels. Remove all but the top screws on each side of the front and rear flue collector panels. The panels can be swung outward and propped up to reveal the heat exchanger. Remove all heat exchanger baffles.

- c. Remove all burners:

CAUTION: *Black carbon or green soot on a dirty heat exchanger can, under certain conditions, be ignited by a random spark or open flame. To prevent this unlikely occurrence, dampen the soot deposits with a wet brush or fine water spray before servicing or cleaning the heat exchanger.*

With a wire brush, remove soot and loose scale from the heat exchanger. Do not use water or compressed air for cleaning. Clean fallen debris from the bottom of the heater. Check that burner ports are clear and pilot assembly is free of debris.

- d. Reassemble in reverse order:

Be sure to replace the heat exchanger baffles.

7. The gas and electric controls installed on the heaters are designed for both dependable operation and long life. But the safety of this equipment depends completely on their proper functioning. It is strongly recommended that the basic items be checked by a competent service technician every year, and replaced when necessary. The basic controls are:
- Water temperature controls.
 - Pilot safety system.
 - Automatic electric gas valve(s).
 - Flow sensing safety device.
8. Low water cutoffs should be inspected every six (6) months, including flushing or float types.

Note: *Warranty does not cover any damage caused by lack of required maintenance or improper operating practices.*

9. Both modulating and staged valves are adjusted at the factory for minimum permissible rates, and should not be readjusted.

Section 5

Troubleshooting and Analysis of Service Problems

- For proper service and problem diagnosis of the heater and heater system, the following tools are required:
 - Gas pressure test kit with range from zero to 14" W.C. Either a slack tub manometer or an accurate gas pressure gauge is acceptable with proper adaptors which will connect to the available fittings in the line and on the gas valve.
 - Electric meter(s) with the following ranges:
 - 0 to 500 volts A.C.
 - 0 to 1000 ohms continuity.
 - Millivolt meter with the following ranges:
 - 0 to 50 millivolts
 - 0 to 500 millivolts
 - 0 to 1000 millivolts
 - Tube cleaning kit consisting of reamer, stainless steel brush, speed handle and handle extensions.
 - Heater thermometer (with 1/2" NPT well)
 - 100-240° F.
- In addition, the heater should be equipped with a system pressure gauge and a thermometer with proper ranges for heater operation.

3. Heater will not fire.

Possible Cause	What To Do
A. Electric power is off	A. Check to see that main power switch is "ON." Use testing device to trace power to heater junction box.
B. Operating or safety control has opened circuit to electric gas valve.	B. Turn off power. Use continuity across terminals of each operating and safety control switch up to the electric gas valve. Replace effective control.
C. Pilot flame is out.	C. Relight pilot per instruction.
D. Manual reset device has tripped.	D. Follow instructions for start-up. Reset pilot safety and all manual reset safety switches and reset manual safety gas valve.
E. No gas pressure to burners.	E. Trace gas line to service shut-off cock. If service cock is open, trace gas line to meter. If no pressure is present at meter, call for public utility service. If gas is present in heater inlet, check pressures in following sequence: (1) downstream from pressure regulator. (2) downstream from electric gas valve. Replace or adjust as necessary.
F. Electric gas valve operator is burned out or shortened.	F. Disconnect wiring harness at gas valve terminals. Check continuity to actuator coil. If open circuit or short is indicated, replace coil or operator.

4. Pressure relief valves leaking intermittently or steadily.

Possible Cause	What To Do
A. Static pressure in system exceeds setting of relief valve.	A. Calculate height of water in system above heater. Install new valve with psi setting 25% above required static system working pressure. Do not exceed 160 psi.
B. Expansion tank is waterlogged (if installed).	B. Drain expansion tank, then reopen it to the system. Look for leaks in expansion tank or fittings. Calculate required volume of expansion tank in relation to system to determine that tank is adequate.

5. Heater is pounding, knocking or emitting steam from relief valves.

Possible Cause	What To Do
A. Low or no water flow.	A. This condition is usually caused by lack of adequate water flow through heater. Check the following: <ol style="list-style-type: none"> 1. Is the heater wired into the pump circuit so that the heater cannot fire unless the pump is running? 2. Check to see that all valves system are open to be sure that water can circulate through the heater and the system. 3. If the system has automatic water valves (2-way or 3-way) that can cut off the water flow through the heater; check to see that they are equipped with end-switches which shut the heater down when the water flow through the heater is reduced by 70% from full flow. 4. Examine pump for clogged impeller.
B. Low or no system pressure	B. Clean strainer in pressure reducing valve. Look for closed valve water line or a leak in the system.
C. Clogged "Y" strainer.	C. Remove strainer element and clean screen.
D. Debris from system piping is blocking tubes	D. Remove header covers. Examine all tubes and waterways. Use new gaskets when reassembling. Clean out tubes.
E. Scale has formed in tubes.	E. This is always caused by the inflow of raw water into the system. Clean tubes with tube cleaning kit. Determine hardness. Check water flow, replace pump for modified flow if necessary.

6. Soot in flueways or in tubes, or noxious fumes indicative or bad combustion.

Possible Cause	What To Do
A. Combustion air supply to heater room is inadequate.	A. Check air supply opening. Look for debris in screen or louvre which covers combustion air opening, or for material blocking the opening.
B. Stack or vent is blocked or restrictive	B. Look for blocked stack and excessive number of elbows in stack or excessive length of horizontal runs.
C. Severe down draft is causing spillage of flue products into room.	C. Check for (1) proper vent cap on stack; (2) adequate height of stack above roof; (3) equipment exhausting air from inside of building; and (4) proper installation of draft diverter.
D. Gas pressure to burners is excessive.	D. Check gas pressure with manometer, and adjust with heater firing at full rate.
E. Heater not fitted for the fuel being supplied.	E. See nameplate for correct fuel.
F. Heater installed at high altitude without proper derating.	F. Installations at altitudes in excess of 2000 ft. above sea level are subject to jurisdiction of the local inspection authorities.

7. Water dripping in firebox.

Possible Cause	What To Do
A. If heater is used with an air conditioning system, chilled water may be flowing either by gravity or pressure through boiler and creating condensate on boiler tubes.	A. Install flow-check valve or programmed bypass valve in the system for change-over from heating to cooling.
B. Tube in heat exchanger has overheated and ruptured.	B. A tube failure always caused by (a) scale formation in the tube or (b) inadequate water flow through the boiler.

Section 6 Conversion of VW from Indoor to Outdoor Models

Please read the following instructions with **Figure 16**.

Figure 17 shows the conversion completed.

Please follow the instructions in their numerical order, failure to do this will cause problems on assembly.

CONVERSION PROCEDURE

SECTION I: (See **Figure 16**)

1. Remove top panel. (1)
2. Remove front and rear upper panels. (2)
3. Remove front and rear wings LH & RH. (3)
4. Remove diverter assembly. (4)
5. Remove outer screw from upper end panel at junction with lower end panel.
6. Remove and disconnect all probes and wires going to castings and gas train.
7. Remove control box assembly - front of heater. (not shown)

SECTION II: (See **Figure 17**)

1. Install front LH & RH extension panels (flush with top of upper end panel). (18)
2. Install rear LH & RH extension panels (flush with top of upper end panel). (15) (pick up holes provided into LB upper and lower end panels)
3. Install front bottom panel. (21)
4. Install rear bottom panel. (14)
5. Install front inner baffles (2) 4" from ends. (17)
6. Install rear inner baffle (1) 2" from ends. (16)
7. Install front LH & RH upper spacers. (27)
8. Install rear LH & RH upper spacers. (7)
9. Install front flue collector extension (screw onto flange of lower flue collector **only**). (28)
10. Install rear flue collector extension (screw onto flange of lower flue collector **only**). (8)
11. Install rear upper panel and remaining screws from flue collector extension. (12)

12. Install middle rear panel. (13)
13. Install front panel making sure opening for removable panel is **square**. (19)
14. Install front stiffener sizes 2450 and up.
15. Install remaining screws from flue collector extension.
16. Install rear top half panel. (5)
17. Install front top half panel. (6)
18. Install front wire (26) mesh using angle (24) at top and strap (25) at bottom (mesh to be inserted under angles of wind baffle stand offs).
19. Install rear mesh same as Step 18.
20. Install front LH & RH wind baffle stand off. (23)
21. Install rear LH & RH wind baffle stand off. (23)
22. Install front and rear wind baffles. (22)
23. Install middle rear baffle stand off. (11)
24. Install middle rear baffle. (10)
25. Install wires control box parts onto control panel. (200185)
26. Install control panel assembly using holes and bushings provided in RH extension panel for probes and wires (not shown).
27. Install removable panels. (20)

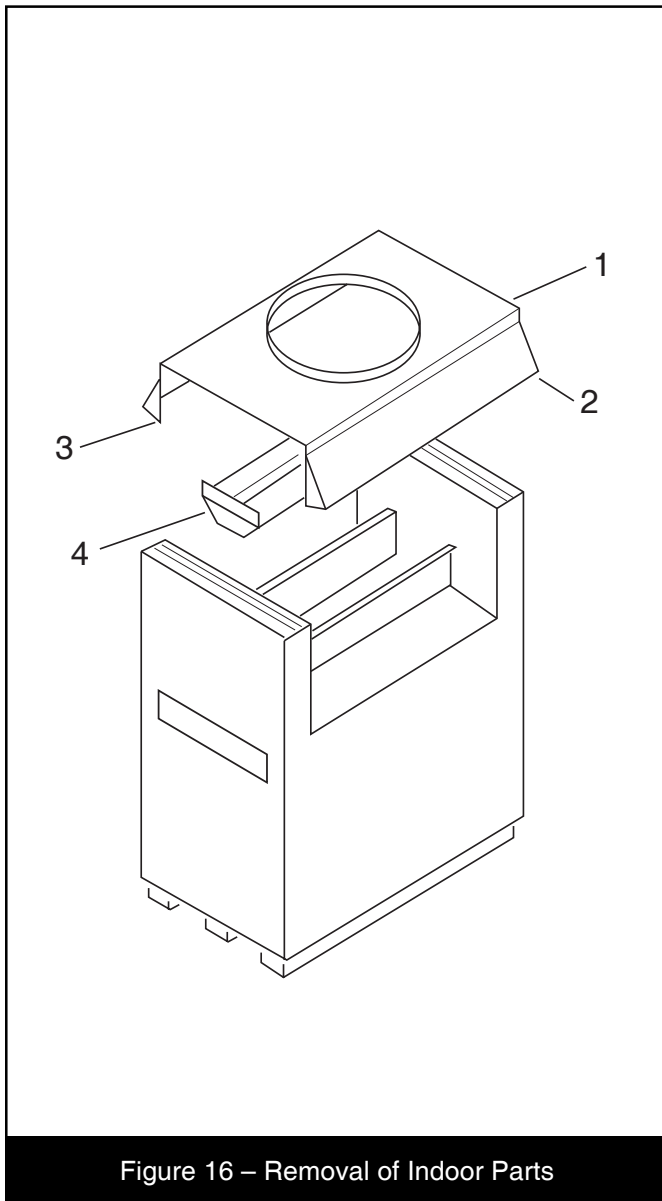

Figure 16 – Removal of Indoor Parts

OUTDOOR KIT PARTS LIST (see Figure 17)

Key No.	Part No.
5	20017100
6	20016900
7	20015101
.....	20015102
8	20016700
9	20017200
10	20017300
11	20017700
12	20016500
13	20016600
14	20016300
15	20014301
.....	20014302
16	20015200
17	20015300
18	20014601
.....	20014602
19	20016100
20	20018000
21	20016200
22	20017200
23	20017600
24	20018200
25	20018300
26	20018600
27	20015001
.....	20015002
28	20016800

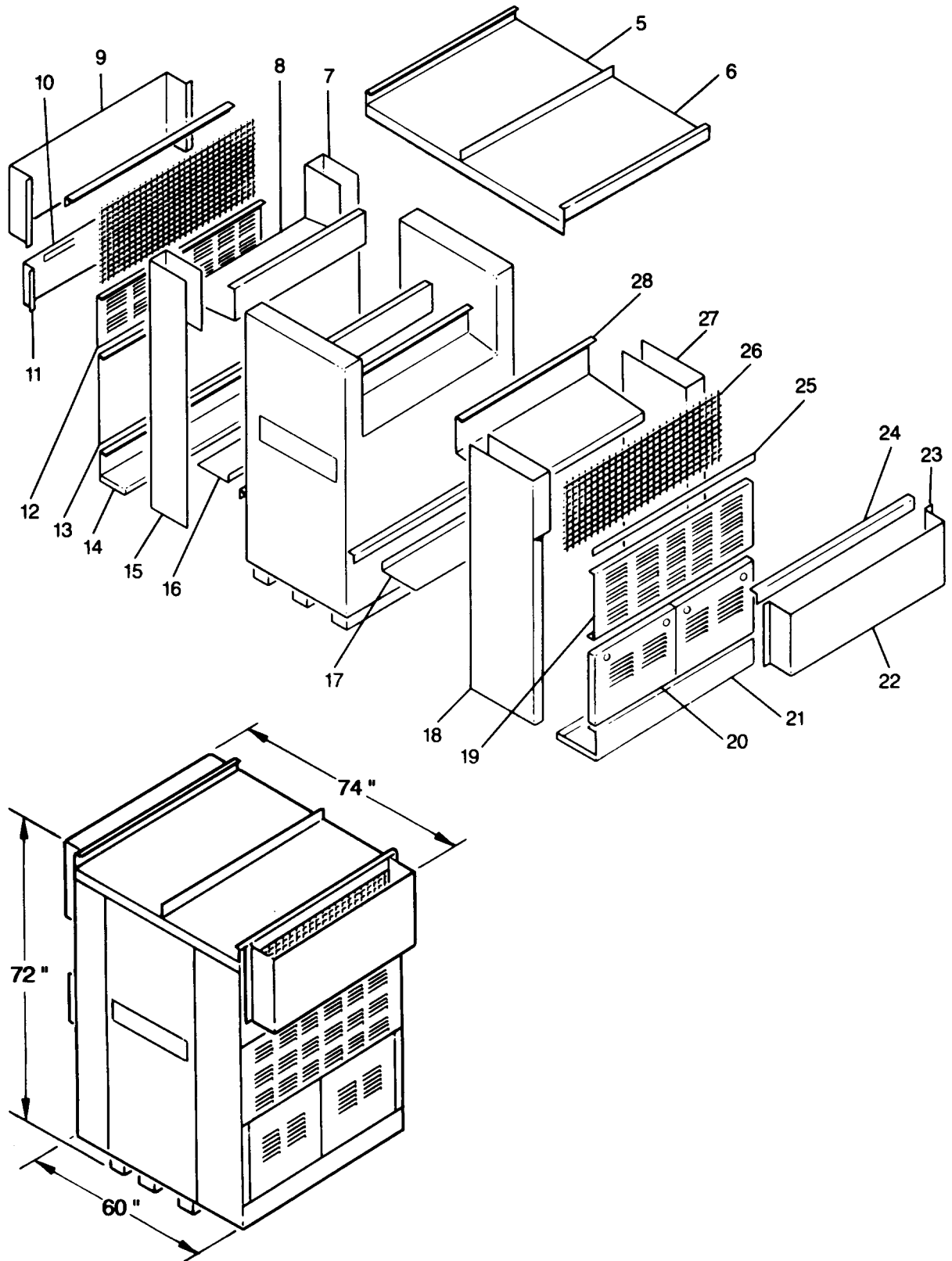

Figure 17 – Outdoor Parts Identification

Key No.	Description	Size 2000 I	Size 2450 I 2200 E	Size 3050 I 2800 E	Size 3500 I 3200 E	Size 4050 I 3600 E	Size 4500 I 4000 E	Size 5000 I 4500 E
1.	Base Weldment Assembly	20067201	20067202	20067203	20067204	20067205	20067206	20067207
2.	Base Assembly	20011001	20011002	20011003	20011004	20011005	20011006	20011007
3.	Center Heat Shield Assembly	20005701	20005702	20005703	20005704	20005705	20005706 (2)	20005707 (2)
3a.	Center Heat Shield Panel	20005601	20005602	20005603	20005604	20005605	20005606 (2)	20005607 (2)
4.	End Tile Rail Support Assembly (left)	20011101	20011101	20011101	20011101	20011101	20011101	20011101
4a.	End Tile Rail Support Assembly (right)	20011102	20011102	20011102	20011102	20011102	20011102	20011102
5.	Manifold Assy. Single Manifold Assy. Split	20064301 20064302	20064201 20064202	20064401 20064402	20064501 20064502	20064600 20064600	20064700 20064700	20064800 20064800
6a.	Main Burner Assembly Pilot Burner Bracket	20012600 (1)	20012600 (1)	20012600 (2)	20012600 (2)	20012600 (2)	20012600 (2)	20012600 (2)
6b.	Main Burner (without pilot bracket)	L2005800 (22)	L2005800 (27)	L2005800 (32)	L2005800 (37)	L2005800 (44)	L2005800 (48)	L2005800 (54)
7.	Inner Shield	20002300 (2)	20002300 (2)	20002300 (2)	20002300 (2)	20002300 (2)	20002300 (2)	20002300 (2)
8.	End Tile Channel	20002600 (2)	20002600 (2)	20002600 (2)	20002600 (2)	20002600 (2)	20002600 (2)	20002600 (2)
9.	Front Lower Closure	20004301	20004302	20004303	20004304	20004305	20004306	20004307
10.	Rear Tile Rail Assembly	20011401	20011402	20011403	20011404	20011405	20011406	20011407
11.	Front Tile Rail Assembly	20011301	20011302	20011303	20011304	20011305	20011306	20011307
12.	Rear Closure Assembly	20012401	20012402	20012403	20012404	20012405	20012406	20012407
13.	Heat Shield Support Bracket	20003201 (2)	20003202 (2)	20003203 (2)	20003204 (2)	20003205 (2)	20003206 (2)	20003207 (2)
14.	Tile Heat Shield Assembly	20012101 (2)	20012102 (2)	20012103 (2)	20012104 (2)	20012105 (2)	20012106 (2)	20012107 (2)
15.	Lower Panel Assembly F & R	20011601 (2)	20011602 (2)	20011603 (2)	20011604 (2)	20011605 (2)	20011606 (2)	20011607 (2)
16.	Tile Cover	20005801 (2)	20005802 (2)	20005803 (2)	20005804 (2)	20005805 (2)	20005806 (2)	20005807 (2)
17.	Saddle Assembly End Tile	10533601 (2)	10533601 (2)	10533601 (2)	10533601 (2)	10533601 (2)	10533601 (2)	10533601 (2)
18-19.	Tile Assembly	See Tile Drawing on Page 20						
20.	Center Support Assembly	20004900	20004900	20004900	20004900	20004900	20004900	20004900
21.	Heat Exchanger Assembly	single pass 20012801 double pass 20001301	20012802 20001302	20012803 20001303	20012804 20001304	20012805 20001305	20012806 20001306	20012807 20001307
21a.	Gasket, Header	S0095300	S0095300	S0095300	S0095300	S0095300	S0095300	S0095300
21b.	Water Barrier	10397500	10397500	10397500	10397500	10397500	10397500	10397500
21c.	Double Pass Header	10416200	10416200	10416200	10416200	10416200	10416200	10416200

I=Indoor, E=Outdoor

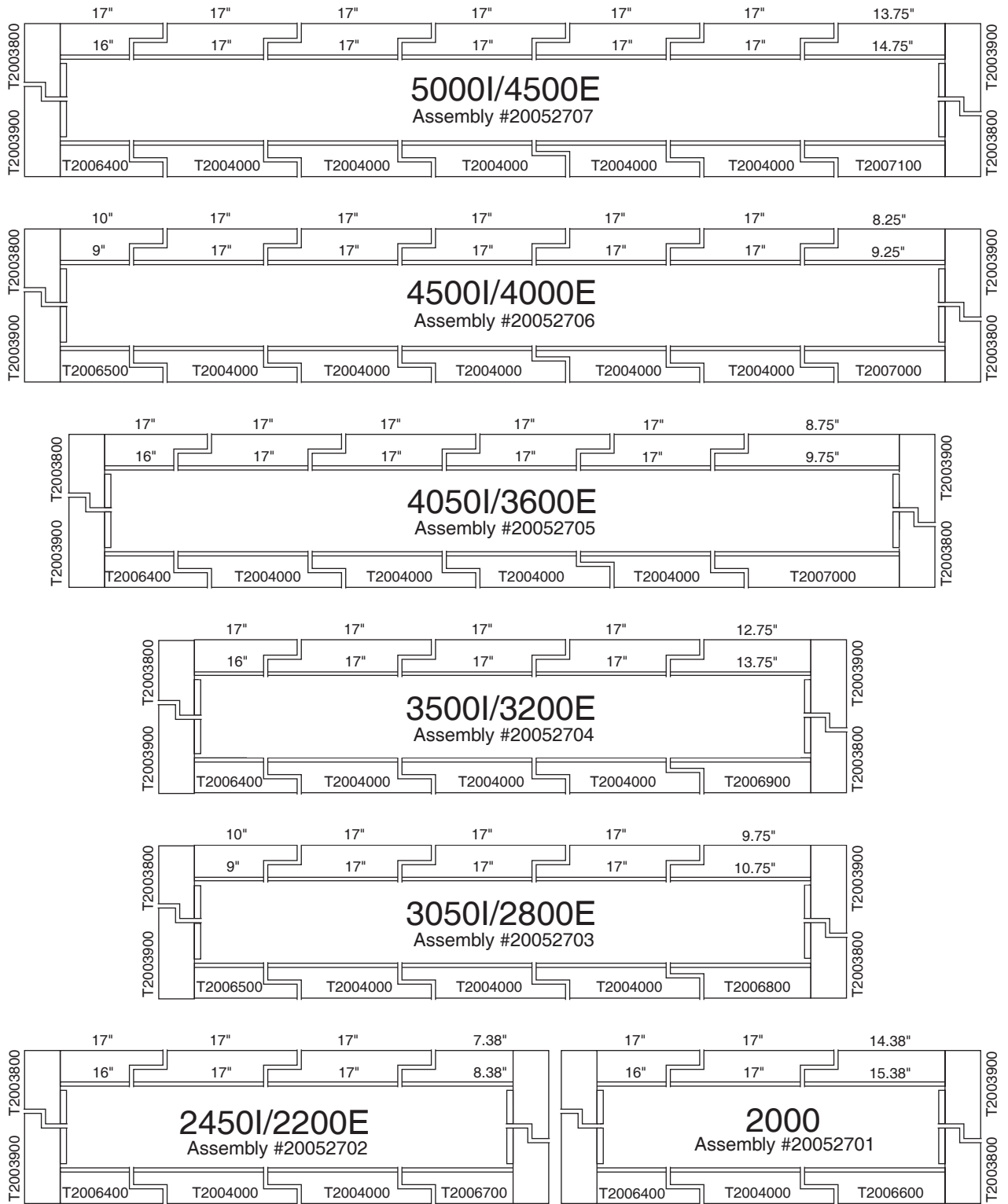
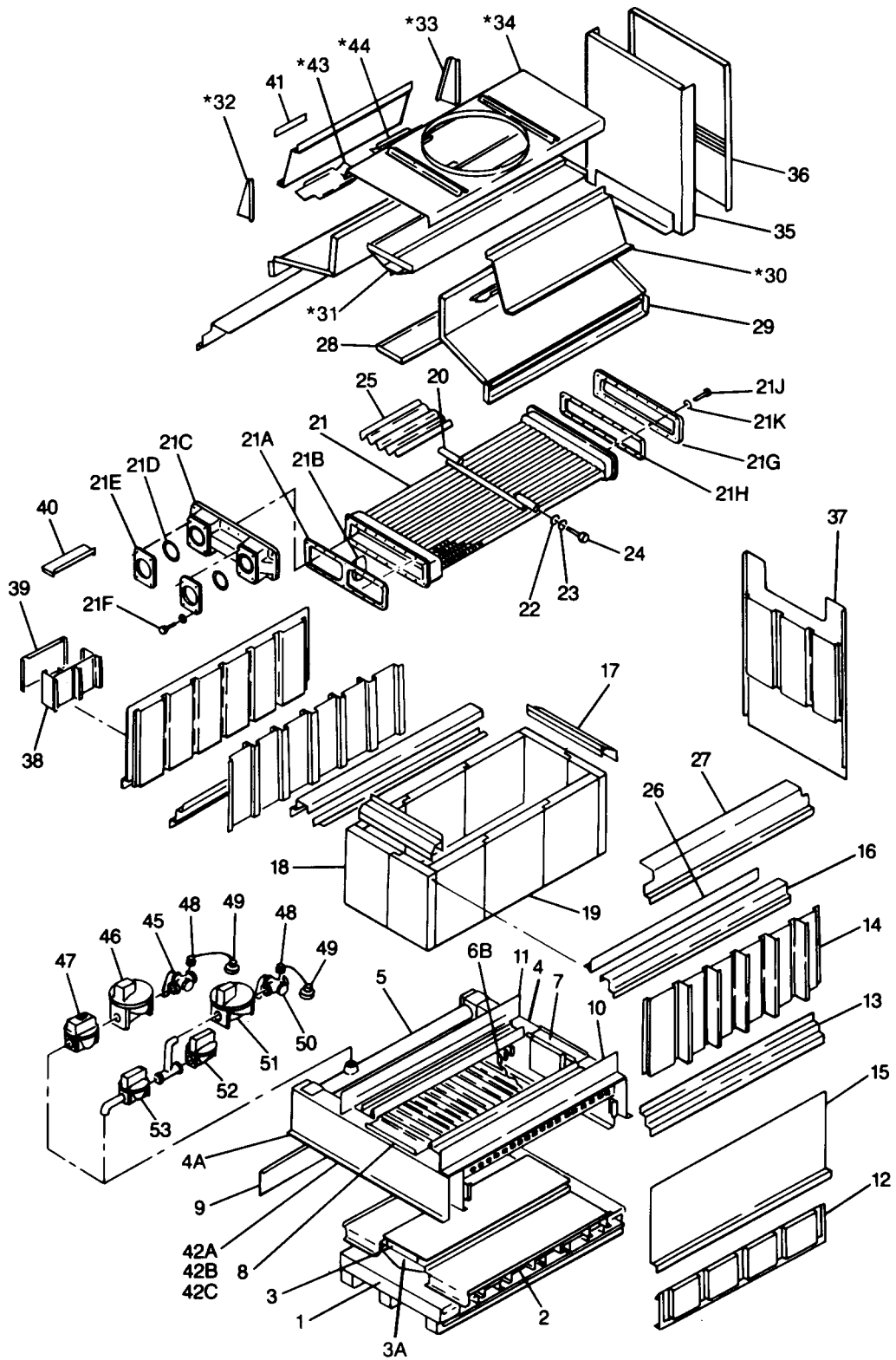

Figure 18 – Tile Assemblies

Key No.	Description	Size 2000 I	Size 2450 I 2200 E	Size 3050 I 2800 E	Size 3500 I 3200 E	Size 4050 I 3600 E	Size 4500 I 4000 E	Size 5000 I 4500 E
21d.	Gasket, Flange	S0095600 (2)	S0095600 (2)	S0095600 (2)	S0095600 (2)	S0095600 (2)	S0095600 (2)	S0095600 (2)
21e.	Flange	10417400 (2)	10417400 (2)	10417400 (2)	10417400 (2)	10417400 (2)	10417400 (2)	10417400 (2)
21f.	Cap Screw-Hex. Hd. 1/2" - 13UNC x 2"	F0024500 (8)	F0024500 (8)	F0024500 (8)	F0024500 (8)	F0024500 (8)	F0024500 (8)	F0024500 (8)
21g.	Return Header	10416100	10416100	10416100	10416100	10416100	10416100	10416100
21h.	Gasket, Header	S0095300	S0095300	S0095300	S0095300	S0095300	S0095300	S0095300
21j.	Cap Screw-Hex. Hd. 1/2" - 13UNC x 1 1/2"	F0013300 (36)	F0013300 (36)	F0013300 (36)	F0013300 (36)	F0013300 (36)	F0013300 (36)	F0013300 (36)
21k.	Washer - 1/2"	F0010300 (36)	F0010300 (36)	F0010300 (36)	F0010300 (36)	F0010300 (36)	F0010300 (36)	F0010300 (36)
22.	Lock Washer - 3/8"	F0010800 (2)	F0010800 (2)	F0010800 (2)	F0010800 (2)	F0010800 (2)	F0010800 (2)	F0010800 (2)
23.	Washer - 3/8"	F0011100 (2)	F0011100 (2)	F0011100 (2)	F0011100 (2)	F0011100 (2)	F0011100 (2)	F0011100 (2)
24.	Cap Screw 3/8" - 16UNC x 3/4"	F0015900 (2)	F0015900 (2)	F0015900 (2)	F0015900 (2)	F0015900 (2)	F0015900 (2)	F0015900 (2)
25.	Heat Exchanger Baffle Assembly	20010900 (68)	20010900 (68)	20010900 (68)	20010900 (102)	20010900 (102)	20010900 (102)	20010900 (102)
26.	Heat Exchanger Baffle F & R	10534310 (2)	10534311 (2)	10534312 (2)	10534313 (2)	10534314 (2)	10534315 (2)	10534316 (2)
27.	Front & Rear Closure	20006401 (2)	20006402 (2)	20006403 (2)	20006404 (2)	20006405 (2)	20006406 (2)	20006407 (2)
28.	Inside Baffle Assembly	Indoor Outdoor 20012501 N/A	20012502 20012509	20012503 20012510	20012504 20012511	20012505 20012512	20012506 20012513	20012507 20012514
29.	Flue Panel Assembly F & R	20011501 (2)	20011502 (2)	20011503 (2)	20011504 (2)	20011505 (2)	20011506 (2)	20011507 (2)
30.	Upper Panel F & R (indoor only)	20011701 (2)	20011702 (2)	20011703 (2)	20011704 (2)	20011705 (2)	20011706 (2)	20011707 (2)
31.	Flue Diverter Assembly (indoor only)	20012201	20012202	20012203	20012204	20012205	20012206	20012207
32.	Upper Wing F & R, Left (indoor only)	20006301 (2)	20006301 (2)	20006301 (2)	20006301 (2)	20006301 (2)	20006301 (2)	20006301 (2)
33.	Upper Wing F & R, Right (indoor only)	20006302 (2)	20006302 (2)	20006302 (2)	20006302 (2)	20006302 (2)	20006302 (2)	20006302 (2)
34.	Top Panel Assembly (indoor only)	20012301	20012302	20012303	20012304	20012305	20012306	20012307
35.	Flue End Assembly	20012000 (2)	20012000 (2)	20012000 (2)	20012000 (2)	20012000 (2)	20012000 (2)	20012000 (2)
36.	Upper End Assembly	20011900 (2)	20011900 (2)	20011900 (2)	20011900 (2)	20011900 (2)	20011900 (2)	20011900 (2)
37.	Lower End Panel Assembly	20011800 (2)	20011800 (2)	20011800 (2)	20011800 (2)	20011800 (2)	20011800 (2)	20011800 (2)
38.	Control Mounting Panel	20013700	20013700	20013700	20013700	20013700	20013700	20013700
39.	Control Cover - Front	20018700	20018700	20018700	20018700	20018700	20018700	20018700
40.	Control Box Cover Top	20011200	20011200	20011200	20011200	20011200	20011200	20011200

I=Indoor, E=Outdoor



* Asterisk = indoor parts only.

Figure 19 – Parts Identification

Key No.	Description	Size 2000 I	Size 2450 I 2200 E	Size 3050 I 2800 E	Size 3500 I 3200 E	Size 4050 I 3600 E	Size 4500 I 4000 E	Size 5000 I 4500 E
41.	Logo Plate	H2000100	H2000100	H2000100	H2000100	H2000100	H2000100	H2000100
42.	Pilot	W0034500 (1)	W0034500 (1)	W0034500 (2)	W0034500 (2)	W0034500 (2)	W0034500 (2)	W0034500 (2)
42a.	Lead Insulator 23.5	10418817 (1)	10418817 (1)	10418817 (2)	10418817 (2)	10418817 (2)	10418817 (2)	10418817 (2)
42b.	Lead Insulator 24.5	10418818 (1)	10418818 (1)	10418818 (2)	10418818 (2)	10418818 (2)	10418818 (2)	10418818 (2)
42c.	Pilot Shield	20016400 (1)	20016400 (1)	20016400 (2)	20016400 (2)	20016400 (2)	20016400 (2)	20016400 (2)
43.	Draft Hood Relief Baffle - Right (indoor only)	20013801 (2)	20013801 (2)	20013801 (2)	20013801 (2)	20013802 (2)	20013803 (2)	20013804 (2)
44.	Draft Hood Relief Baffle - Right (indoor only)	20013805 (2)	20013805 (2)	20013805 (2)	20013805 (2)	20013806 (2)	20013807 (2)	20013808 (2)
45.	Manual Valve	V0001800	V0001800	V2013800	V2013800	V2013800	V2013900	V2013900
46.	Safety Valve	V0046800	V0046800	V0046900	V0046900	V0046900	V2000500	V2000500
47.	Operating Valve	V0051400 (1)	V0051400 (1)	V2001000 (1)	V0051400 (2)	V0051400 (2)	V0051400 (2)	V0051400 (2)
48.	Pilot Regulator	W0002000 (1)	W0002000 (1)	W0002000 (2)	W0002000 (2)	W0002000 (2)	W0002000 (2)	W0002000 (2)
49.	Pilot Valve	W0019300 (1)	W0019300 (1)	W0019300 (2)	W0019300 (2)	W0019300 (2)	W0019300 (2)	W0019300 (2)
50.	Manual Valve	V0059700	V0059700	V2013800	V2013800	V2013800	V2013900	V2013900
51.	Regulator	V0026700	V0026900	V0026900	V0026900	V0027000	V0027000	V0027000
52.	Safety Valve	V0046800	V0046900	V0046900	V0046900	V2000500	V2000500	V2000500
53.	Modulator Valve	V0048400	V0048400	V0048400	V0048400	V0048500	V0048500	V0048600



H2110000A

National Combustion Company, Inc.
104-07 180th Street, Jamaica, NY 11433 • (718) 291-8400 FAX (718) 291-6870
Litho in U.S.A. © 0610